

Engine: All Technical Service Bulletins

Technical Service Bulletin # **04-06-01-029E**

Date: **100429**

Vehicle - Engine Crankcase and Subsystems Flushing Info. INFORMATION

Bulletin No.: 04-06-01-029E

Date: April 29, 2010

Subject: Unnecessary Flushing Services, Additive Recommendations and Proper Utilization of GM Simplified Maintenance Schedule to Enhance Customer Service Experience

Models:

2011 and Prior GM Passenger Cars and Trucks (including Saturn)

2010 and Prior HUMMER H2, H3

2005-2009 Saab 9-7X

Supersede:

This bulletin is being revised to update the model years and add information about the proper transmission flush procedure. Please discard Corporate Bulletin Number 04-06-01-029D (Section 06 - Engine/Propulsion System).

An Overview of Proper Vehicle Service

General Motors is aware that some companies are marketing tools and equipment to support a subsystem flushing procedures. These dedicated machines are in addition to many engine oil, cooling system, fuel system, A/C, transmission flush and steering system additives available to the consumer. GM Vehicles under normal usage do not require any additional procedures or additives beyond what is advised under the former Vehicle Maintenance Schedules or the current Simplified Maintenance Schedules. Do not confuse machines available from Kent-Moore/SPX that are designed to aid and accelerate the process of fluid changing with these flushing machines.

Engine Crankcase Flushing

General Motors Corporation does not endorse or recommend engine crankcase flushing for any of its gasoline engines. Analysis of some of the aftermarket materials used for crankcase flushing indicate incompatibility with GM engine components and the potential for damage to some engine seals and bearings. Damage to engine components resulting from crankcase flushing IS NOT COVERED under the terms of the New Vehicle Warranty.

GM Authorized Service Information: Detailed, Descriptive, and Complete

If a specific model vehicle or powertrain need is identified, GM will issue an Authorized Service Document containing a procedure and, if required, provide, make available, or require the specific use of a machine, tool or chemical to accomplish proper vehicle servicing. An example of this is fuel injector cleaning. Due to variation in fuel quality in different areas of the country, GM has recognized the need for fuel injector cleaning methods on some engines, though under normal circumstances, this service is not part of the maintenance requirements.

GM has published several gasoline fuel injector cleaning bulletins that fully outline the methods to be used in conjunction with GM Part Numbered solutions to accomplish proper and safe cleaning of the fuel injectors with preventative maintenance suggestions to maintain optimum performance. You may refer to Corporate Bulletin Numbers 03-06-04-030 and 04-06-04-051 for additional information on this subject.

Subsystem Flushing

Flushing of A/C lines, radiators, transmission coolers, and power steering systems are recognized practices to be performed after catastrophic failures or extreme corrosion when encountered in radiators. For acceptable A/C flushing concerns, refer to Corporate Bulletin Number 01-01-38-006. This practice is NOT required or recommended for normal service operations.

The use of external transmission fluid exchange or flush machines is **NOT** recommended for the automatic or manual transmission. Use of external machines to replace the fluid may affect the operation or durability of the transmission. Transmission fluid should only be replaced by draining and refilling following directions in SI. Refer to Automatic/Manual Transmission Fluid and Filter Replacement.

Approved Transmission Flushing Tool (Transmission Cooler Only)

The Automatic Transmission Oil Cooler Flush and Flow Test Tool is recommended for GM vehicles. Refer to Transmission Fluid Cooler Flushing and Flow Test in SI using the J 45096.

Service Is Important to You and Your Customer

General Motors takes great pride in offering our dealerships and customers high quality vehicles that require extremely low maintenance over the life of the vehicle. This low cost of ownership builds repeat sales and offers our customers measurable economy of operation against competing vehicles. Providing responsible services at the proper intervals will greatly aid your dealership with repeat business, and additional services when required. Most customers appreciate and gain trust in the dealership that informs and offers them just what they need for continued trouble-free operation. Examine your service department's practices and verify that all Service Consultants and Technicians focus on customer satisfaction, vehicle inspections, and other products at time of service. Use this opportunity to upgrade the services you provide to your customers. Here are a few suggestions:

- Take the time required to align your dealership service practices with the new GM Simplified Maintenance Schedule. Use the new vehicle Owner's Manual Maintenance I and II schedules to create a "mirror image" in your advertising and dealer service pricing that is easily understandable to your customer. Taking advantage of this new service strategy may greatly increase your dealership service sales and customer retention while decreasing the frequency of visits and inconvenience to your customer.
- Review your program to ensure that all vehicles coming in are evaluated for safety and wear items. Examine all vehicles for tire condition, signs of misalignment, brake wear, exterior lamp functionality, exhaust condition, A/C cooling performance, SRS or Air Bag MIL, along with Service Engine Soon or Check Engine indicators. **If the Service Engine Soon or Check Engine MIL is illuminated, it is vital that you inform the customer of the concerns with ignoring the indicator and what the required repair would cost. In addition to the possibility of increased emissions and driveability concerns, many customers are unaware that lower gas mileage may also result, with additional cost to the customer.**
- Be complete in your service recommendations. Some sales opportunities are not being fully pursued nationally. Focus on overlooked but required maintenance that has real benefits to the customer. Many vehicles are equipped with cabin air filters. If these filters are used beyond replacement time, they may impede airflow decreasing A/C and heating performance. Make sure these filters are part of your recommended service. Note that some of our vehicles may not have been factory equipped but will accept the filters as an accessory.
- Express the value in maintaining the finish quality of the customer's vehicle at the Maintenance I and II visits. More fully utilize the vehicle prep personnel you already have in place. In today's world, many people simply ignore the finish of their vehicle, at best infrequently using an automatic car wash for exterior cleaning. Offer vehicle detailing services in stages from just a wash and wax to a complete interior cleaning. When paired with the Simplified Maintenance visit, this will increase customer satisfaction. On return, the customer gets a visibly improved vehicle that will be a source of pride of ownership along with a vehicle that is now fully maintained. Also, reinforce the improved resale value of a completely maintained vehicle.
- For customers who clean and maintain the appearance of their vehicles themselves encourage the use of GM Vehicle Care products. Many customers may have never used GM Car Wash/Wax Concentrate, GM Cleaner Wax or a longtime product, GM Glass Cleaner, which is a favorite of many customers who try it just once. If your dealership give samples of these products with new car purchases, customers may already be sold on the product but not willing to make a special trip to the dealership. Capitalize on sales at this time. Stock shelves right at the Service counter with these products and consider instituting compensation programs for Service Consultants who suggest these products. Many consumers faced with an intimidating wall full of car care products sold at local auto parts stores may find it comforting to purchase a fully tested product sold by GM that they know will not harm the finish of their vehicle. We suggest these competitively priced basic vehicle care products to emphasize:

In USA:

- #12378401 GM Vehicle Care Wash/Wax Concentrate 16 fl. oz. (0.473L)
- #89021822 GM Vehicle Care Glass Cleaner Aerosol 18 oz. (510 g)
- #12377966 GM Vehicle Care Cleaner Wax 16 fl. oz. (0.473L)
- #1052929 GM Vehicle Care Chrome and Wire Wheel Cleaner 16 fl. oz. (0.473L)
- #88861431 GM Vehicle Care Odor Eliminator 24 fl. oz. (0.710L)

In Canada:

- #10953203 GM Vehicle Care Wash & Wax Concentrate 473 mL
 - #992727 GM Glass Cleaner Aerosol 500 g
 - #10952905 GM Vehicle Care Liquid Cleaner/Wax 473 mL
 - #10953013 GM Vehicle Care Chrome Cleaner and Polish 454 mL
 - #10953202 GM Vehicle Care Wheel Brite 473 mL
 - #88901678 GM Vehicle Care Odor Eliminator 473 mL
- Display signboards with the installed price for popular GM Accessories such as running boards and Tonneau Covers. Customers may not think to ask about these desirable items at the time of a service visit.
 - Finally, take advantage of the GM Goodwrench initiatives (Tire Program, Goodwrench Credit Card, etc. / Dealer Marketing Association (DMA) Promotions in Canada) to provide the customer with more reasons to identify your dealership as the best place to go for parts and service.

Remember to utilize ALL of the service aspects you possess in your dealership to satisfy and provide value to your customer. Many businesses exist profitably as an oil change location, a vehicle repair facility, or a detailing shop alone. You already have the capabilities of all three and provide these services with the inherent trust of your customer, under the GM Mark of Excellence.

GM bulletins are intended for use by professional technicians, NOT a "do-it-yourselfer". They are written to inform these technicians of conditions that may occur on some vehicles, or to provide information that could assist in the proper service of a vehicle. Properly trained technicians have the equipment, tools, safety instructions, and know-how to do a job properly and safely. If a condition is described, DO NOT assume that the bulletin applies to your vehicle, or that your vehicle will have that condition. See your GM dealer for information on whether your vehicle may benefit from the information.



WE SUPPORT
VOLUNTARY
TECHNICIAN
CERTIFICATION

Disclaimer

Technical Service Bulletin # **00-06-01-026C**

Date: **100203**

Engine - Intake Manifold Inspection/Replacement INFORMATION

Bulletin No.: 00-06-01-026C

Date: February 03, 2010

Subject: Intake Manifold Inspection/Replacement After Severe Internal Engine Damage

Models:

2010 and Prior Passenger Cars and Trucks (Including Saturn)

2010 and Prior HUMMER H2, H3

2009 and Prior Saab 9-7X

Supercede:

This bulletin is being revised to include additional model years. Please discard Corporate Bulletin Number 00-06-01-026B (Section 06 - Engine).

When replacing an engine due to internal damage, extreme care should be taken when transferring the intake manifold to the new Goodwrench service engine long block. Internal damage may result in the potential discharge of internal engine component debris in the intake manifold via broken pistons and/or bent, broken, or missing intake valves. After removing the intake manifold from the engine, the technician should carefully inspect all of the cylinder head intake ports to see if the valve heads are still present and not bent. Usually when the valve heads are missing or sufficiently bent, internal engine component debris will be present to varying degrees in the intake port of the cylinder head. If this debris is present in any of the cylinder head intake ports, the intake manifold should be replaced. This replacement is required due to the complex inlet runner and plenum configuration of most of the intake manifolds, making thorough and complete component cleaning difficult and nearly impossible to verify complete removal of debris.

Re-installation of an intake manifold removed from an engine with deposits of internal engine component debris may result in the ingestion of any remaining debris into the new Goodwrench service engine. This may cause damage or potential failure of the new service engine.

GM bulletins are intended for use by professional technicians, NOT a "do-it-yourselfer". They are written to inform these technicians of conditions that may occur on some vehicles, or to provide information that could assist in the proper service of a vehicle. Properly trained technicians have the equipment, tools, safety instructions, and know-how to do a job properly and safely. If a condition is described, DO NOT assume that the bulletin applies to your vehicle, or that your vehicle will have that condition. See your GM dealer for information on whether your vehicle may benefit from the information.



WE SUPPORT
VOLUNTARY
TECHNICIAN
CERTIFICATION

Disclaimer

Technical Service Bulletin # **08-06-01-008A**

Date: **090727**

Engine - Drive Belt Misalignment Diagnostics INFORMATION

Bulletin No.: 08-06-01-008A

Date: July 27, 2009

Subject: Diagnosing Accessory Drive Belt / Serpentine Belt Noise and Availability and Use of Kent-Moore EN-49228 Laser Alignment Tool - Drive Belt

Models:

2010 and Prior GM Passenger Cars and Trucks (Including Saturn)

2010 and Prior HUMMER H2, H3 Vehicles

2009 and Prior Saab 9-7X

Supersede:

This bulletin is being revised to add a model year and update the Tool Information. Please discard Corporate Bulletin Number 08-06-01-008 (Section 06 - Engine).

Background

Several aftermarket companies offer laser alignment tools for accessory drive systems that can be very helpful in eliminating drive belt noise as a result of misaligned pulleys. Typically pricing ranges from \$160 - \$200.

EN-49228 Laser Alignment Tool - Drive Belt

The GM Tool program has now made available a competitive, simple to use and time-saving laser tool to assist in achieving precise alignment of the drive belt pulleys. This optional tool removes the guesswork from proper pulley alignment and may serve to reduce comebacks from:

- Drive Belt Noise
- Accelerated Drive Belt Wear
- Drive Belt Slippage

Instructions

The instructions below are specific only to the truck Gen IV V-8 family of engines. These instructions are only for illustrative purposes to show how the tool may be used. Universal instructions are included in the box with the Laser Alignment Tool - Drive Belt.

Caution

- Do not look directly into the beam projected from the laser.
- Use caution when shining the laser on highly polished or reflective surfaces. Laser safety glasses help reduce laser beam glare in many circumstances.
- Always use laser safety glasses when using the laser. Laser safety glasses are not designed to protect eyes from direct laser exposure.

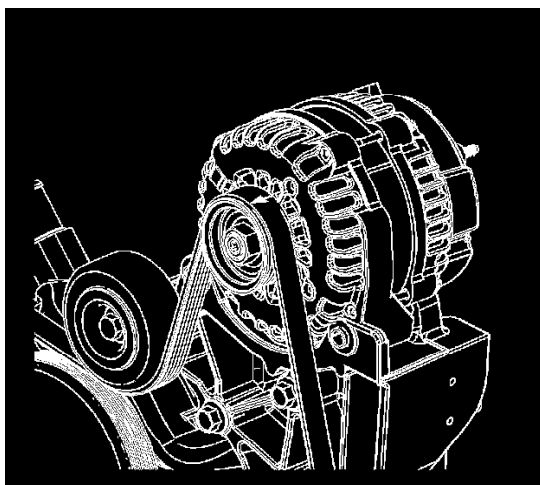

1. Observe and mark the serpentine belt orientation.
2. Remove the serpentine belt from the accessory drive system.

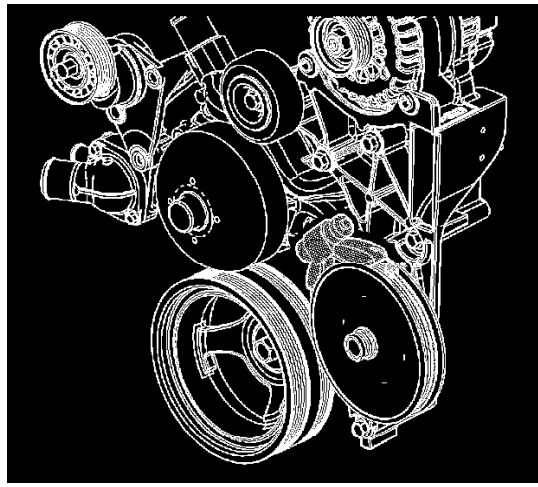

3. Install the tool onto the power steering pulley. Position the legs of the tool into the outer grooves of the pulley, farthest from the front of the engine.
4. Install the retaining cord around the pulley and to the legs of the tool.

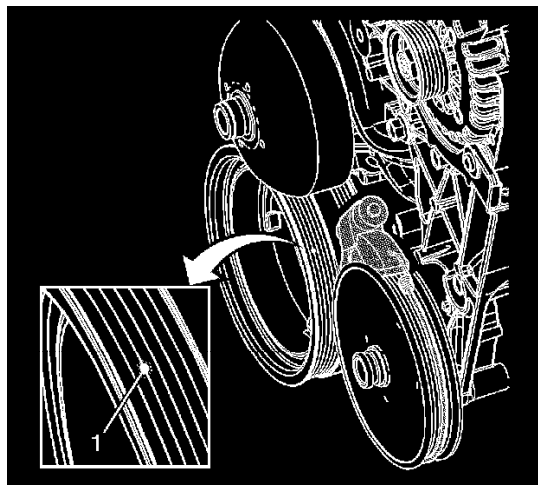

5. Put on the laser safety glasses provided with the tool.
6. Depress the switch on the rear of the tool to activate the light beam.
7. Rotate the power steering pulley as required to project the light beam onto the crankshaft balancer pulley grooves.
8. Inspect for proper power steering pulley alignment.
 - If the laser beam projects onto the second rib or raised area (1), the pulleys are aligned properly.
 - If the laser beam projects more than one-quarter rib 0.9 mm (0.035 in) mis-alignment, adjust the position of the power steering pulley as required.
 - Refer to SI for Power Steering Pulley Removal and Installation procedures.
9. Install the serpentine belt to the accessory drive system in the original orientation.
10. Operate the vehicle and verify that the belt noise concern is no longer present.

Tool Information

GM Tool Number	Description
EN-49228	Laser Alignment Tool - Drive Belt

Please visit the GM service tool website for pricing information or to place your order for this tool.

GM bulletins are intended for use by professional technicians, NOT a "do-it-yourselfer". They are written to inform these technicians of conditions that may occur on some vehicles, or to provide information that could assist in the proper service of a vehicle. Properly trained technicians have the equipment, tools, safety instructions, and know-how to do a job properly and safely. If a condition is described, DO NOT assume that the bulletin applies to your vehicle, or that your vehicle will have that condition. See your GM dealer for information on whether your vehicle may benefit from the information.



WE SUPPORT
VOLUNTARY
TECHNICIAN
CERTIFICATION

Disclaimer

Technical Service Bulletin # 07-06-01-016B

Date: 090727

Engine - Noise/Damage Oil Filter Application Importance INFORMATION

Bulletin No.: 07-06-01-016B

Date: July 27, 2009

Subject: Information on Internal Engine Noise or Damage After Oil Filter Replacement

Models:

2010 and Prior Passenger Cars and Trucks (Including Saturn)

2010 and Prior HUMMER H2, H3

2009 and Prior Saab 9-7X

Supercede:

This bulletin is being updated to add model years. Please discard Corporate Bulletin Number 07-06-01-016A (Section 06 - Engine/Propulsion System).

Important

Engine damage that is the result of an incorrect or improperly installed engine oil filter is not a warrantable claim. The best way to avoid oil filter quality concerns is to purchase ACDELCO(R) oil filters directly from GMSPO.

Oil filter misapplication may cause abnormal engine noise or internal damage. Always utilize the most recent parts information to ensure the correct part number filter is installed when replacing oil filters. Do not rely on physical dimensions alone. Counterfeit copies of name brand parts have been discovered in some aftermarket parts systems. Always ensure the parts you install are from a trusted source. Improper oil filter installation may result in catastrophic engine damage.

Refer to the appropriate Service Information (SI) installation instructions when replacing any oil filter and pay particular attention to procedures for proper cartridge filter element alignment. If the diagnostics in SI (Engine Mechanical) lead to the oil filter as the cause of the internal engine noise or damage, dealers should submit a field product report. Refer to Corporate Bulletin Number 02-00-89-002I (Information for Dealers on How to Submit a Field Product Report).

GM bulletins are intended for use by professional technicians, NOT a "do-it-yourselfer". They are written to inform these technicians of conditions that may occur on some vehicles, or to provide information that could assist in the proper service of a vehicle. Properly trained technicians have the equipment, tools, safety instructions, and know-how to do a job properly and safely. If a condition is described, DO NOT assume that the bulletin applies to your vehicle, or that your vehicle will have that condition. See your GM dealer for information on whether your vehicle may benefit from the information.



WE SUPPORT
VOLUNTARY
TECHNICIAN
CERTIFICATION

Disclaimer

Technical Service Bulletin # 00-06-01-012C

Date: 080414

Engine - Use of 'Surface Conditioning Disks' INFORMATION

Bulletin No.: 00-06-01-012C

Date: April 14, 2008

Subject:

Use of "Surface Conditioning Disks" When Cleaning Engine Gasket Sealing Surfaces and/or Reused Engine Parts

Models:

2009 and Prior GM Passenger Cars and Trucks (including Saturn)

2009 and Prior HUMMER H2 Models, H3

2009 and Prior Saab 9-7X

Supercede:

This bulletin is being revised to add the 2008 and 2009 model years. Please discard Corporate Bulletin Number 00-06-01-012B (Section 06 - Engine/Propulsion System).

The Use of "Surface Conditioning Disks"

Notice:

Do not use abrasive pad/bristle devices to clean the gasket surfaces of engine components. Abrasive pads should not be used for the following reasons:

- ^ Abrasive pads will produce fine grit that the oil filter will not be able to remove from the oil. **THIS GRIT IS ABRASIVE AND HAS BEEN KNOWN TO CAUSE INTERNAL ENGINE DAMAGE.** Abrasive pads can easily remove enough material to round cylinder head surfaces. This has been known to affect the gaskets ability to seal especially in the narrow seal areas between the combustion chambers and coolant jackets.
- ^ Abrasive pads can also remove enough metal to affect cylinder head block oil pan rail and intake manifold runner flatness which can cause coolant and oil leaks. It takes about 15 seconds to remove 0.203 mm (0.008 in) of metal with an abrasive pad.

When cleaning engine gasket sealing surfaces and/or cleaning parts from an engine that are to be reused surface conditioning disks (typically constructed of woven fiber or molded bristles) that contain abrasives such as a high amount of Aluminum Oxide should NOT be used.

The use of such surface conditioning disks dislodges Aluminum Oxide (from the disk) and metal particles which can lead to premature engine bearing failure.

The presence of Aluminum Oxide in engine oil has been shown to cause premature engine bearing failure. In some cases this failure occurs in as little as 2,200 km (1,000 mi) or less after the repair has been made.

Surface conditioning disks may grind the component material and imbed it into the disk. This can result when more aggressive grinding of the gasket surface takes place.

Recommended Cleaning Procedure

General Motors recommends the use of a razor blade or plastic gasket scraper to clean the gasket surface on engine components that are to be reused. When cleaning gasket surfaces please note the following:

- ^ When using a razor blade type gasket scraper use a new razor blade for each cylinder head and corresponding block surface. Hold the blade as parallel to the gasket surface as possible. This will ensure that the razor blade does not gouge or scratch the gasket surfaces.
- ^ Do not gouge or scrape the combustion chamber surfaces.
- ^ Do not gouge or scratch any engine-sealing surface during the cleaning process.

Important:

The appearance of the gasket surface is not critical - the feel is. There will be indentations from the gasket left in the cylinder head after all the gasket material is removed. The new gasket will fill these small indentations when it is installed.

GM bulletins are intended for use by professional technicians, NOT a "do-it-yourselfer". They are written to inform these technicians of conditions that may occur on some vehicles, or to provide information that could assist in the proper service of a vehicle. Properly trained technicians have the equipment, tools, safety instructions, and know-how to do a job properly and safely. If a condition is described, DO NOT assume that the bulletin applies to your vehicle, or that your vehicle will have that condition. See your GM dealer for information on whether your vehicle may benefit from the information.



WE SUPPORT
VOLUNTARY
TECHNICIAN
CERTIFICATION

Disclaimer Technical Service Bulletin # **05-06-01-010B**

Date: **070928**

Engine - Sealant Usage/Procedures

Bulletin No.: 05-06-01-010B

Date: September 28, 2007

INFORMATION

Subject:

Service Information Update on Consolidating Use of GM Liquid Gasket/Engine Sealants and New Sealant Dispenser GE-48326 Essential Tool

Models:

2008 and Prior GM Passenger Cars and Trucks (including Saturn)

2003-2008 HUMMER H2

2006-2008 HUMMER H3

2005-2008 Saab 9-7X

with Gasoline or Diesel Engines

Supercede:

This bulletin is being updated to add additional information about the use by date code printed on the crimp of the sealant tube. Please discard Corporate Bulletin Number 05-06-01-010A (Section 06 - Engine/Propulsion System).

In 2005 General Motors consolidated the use of all liquid gaskets/engine sealants. At that time, two sealants replaced all previous sealants referred to in Service Information (SI) and/or the Service Manual.

In 2007, GM has consolidated to one engine sealant already available in a 150 g cartridge and now in a 75 g aluminum tube. As a result, P/N 12346141, 54 g tube, has been deleted from service.

One of these, engine sealant P/N 12378521 (U.S.) and P/N 88901148 (Canada), was released in a cartridge to be used in a conventional caulking gun. The cartridge and conventional caulking gun proved to be too large and cumbersome in certain instances when used in on-vehicle service.

To address this concern, GM Powertrain Engineering released the engine sealant in a 0.075 kg (75 gram) squeeze tube (packaged six to the carton, with nozzles) along with a new essential service tool, Sealant Dispenser GE-48326, which has been shipped to all GM dealerships.

Sealant Guidelines

The GM Powertrain engineering specification for applying this sealant is an even bead, 3 mm (0.118 in) in diameter. Due to the high viscosity of the sealant, a dispenser is required to meet this specification. The GE-48326 Sealant Dispenser provides the ability to apply the sealant to specification using one hand, even in areas not accessible using the P/N 12378521 Engine Sealant cartridge and caulking gun.

This solitary engine sealant available in tubes and small cartridge is compatible with all synthetic, synthetic blends and mineral oils, as well as all engine coolants including DEX-COOL(R). The maximum working time of this sealant is 20 minutes. The sealant will be fully cured in 24 hours. The assembly may be filled with oil or coolant immediately after applying the sealant and tightening the bolts.

88861417 (U.S.)	Engine Sealant 0.075 kg (75 gram) Squeeze Tube
88861418 (Canada)	
12378521 (U.S.)	Engine Sealant 0.15 kg (150 gram) Cartridge
88901148 (Canada)	

Engine Sealant Part Numbers



Use By Date Code

The 0.075 kg (75 gram) Squeeze Tube is not available for 2008 and prior Saturn models (only in 150 g cartridges).

The "use by" date on the 0.15 kg (150 gram) cartridge currently is not available.

The use by date of the 0.075 kg (75 gram) tube is twelve months from the manufacture date printed on the crimp month (1), date (2), year (3). GMSP0 recommends that dealers use the first-in first out (FIFO) system of stock rotation on chemicals. Use the oldest stock first by rotating the oldest to the front of a stock location.



Special Service Tool GE-48326 Sealant Dispenser



New Engine Sealant 0.075 kg (75 gram) Squeeze Tube (also available in Vehicle Care label for US dealers)

New Sealant and Sealant Dispenser GE-48326

Engine Sealant 0.075 kg (75 gram) Squeeze Tube is not available for 2008 and prior Saturn models (only in 150 g cartridges).

The following service procedures will assist technicians in the proper use of the new sealant dispenser GE-48326 in applying an even bead of sealant 3 mm (0.118 in) in diameter using one hand, even in areas not accessible using engine sealant cartridge and caulking gun.



To use the sealant dispenser correctly, install the two white tabs on the rear handle (1) over the front handle. The white paint marks are for demonstration purposes only. Now your dispenser is ready to install engine sealant 0.075 kg (75 gram) squeeze tube.

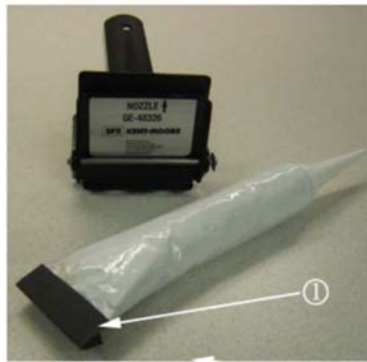

Before installing engine sealant 0.075 kg (75 gram) squeeze tube into the dispenser, install a small piece of medium grit sandpaper, or equivalent, by folding it over the bottom of the squeeze tube (1). This will help hold the squeeze tube firmly in place while using the sealant dispenser.



Install engine sealant 0.075 kg (75 gram) squeeze tube with a small piece of medium grit sandpaper into the dispenser (see above graphic illustration). Remember to open the squeeze tube with a sharp knife or equivalent and cut the sealant nozzle to the correct diameter to apply a 3 mm (0.118 in) even bead of sealant.



The sealant dispenser with the engine sealant is now ready to be used (see above graphic illustration).

GM bulletins are intended for use by professional technicians, NOT a "do-it-yourselfer". They are written to inform these technicians of conditions that may occur on some vehicles, or to provide information that could assist in the proper service of a vehicle. Properly trained technicians have the equipment, tools, safety instructions, and know-how to do a job properly and safely. If a condition is described, DO NOT assume that the bulletin applies to your vehicle, or that your vehicle will have that condition. See your GM dealer for information on whether your vehicle may benefit from the information.



WE SUPPORT
VOLUNTARY
TECHNICIAN
CERTIFICATION

Disclaimer Technical Service Bulletin # 99-00-01-001

Date: 990901

Engine - AC Delco Remanufactured Engines

File In Section: 00 - General Information

Bulletin No.: 99-00-01-001

Date: September, 1999

WARRANTY ADMINISTRATION

Subject:

ACDelco(R) Remanufactured Engines

Models:

1996 and Prior Passenger Cars, Light & Medium Duty Trucks

Attention:

Dealer Service Manager/Parts Manager/Warranty Administrator

Since April, 1993, General Motors Service Parts Operations (GMSPO) has offered ACDelco(R) Remanufactured Engines to GM dealers for a variety of 1996 and prior GM, Ford, and Chrysler model applications. The purpose of this bulletin is to provide you with the most recent enhancements to the ACDelco(R) Remanufactured Engine Warranty Statement, updated administrative procedures, and warranty claim submission requirements.

Warranty Coverage

Effective with purchases on or after February 1, 1999, ACDelco(R) remanufactured engines are covered by a 36 month/36,000 mile, consumer limited replacement parts warranty for Passenger Car and Light Duty Truck applications. The warranty coverage will remain 24 months/24,000 miles for all Passenger Car and Light Duty Truck engines purchased prior to this date. For Taxi & Police Car applications and Medium Duty trucks with a GVW over 16,000 pounds, the coverage is limited to 12 months/12,000 miles. This warranty covers the cost of parts and labor and begins on the date/mileage of retail purchase. Warranty coverage continues to apply to subsequent owners provided the original owner's repair order or sales slip is submitted along with the original owner's copy of the Warranty Registration Form when repairs are requested.

New Warranty Registration

Effective immediately, ACDelco(R) is implementing a Powertrain Warranty Registration process for ACDelco(R) remanufactured engines. This registration process will provide better tracking of our vehicle owner base and improved customer warranty support. A Powertrain Warranty Registration Form, WA-39A, is now included with all ACDelco(R) engines and transmissions being shipped. This form is in triplicate on carbonless paper. One copy is for the vehicle owner, a second is for the installing facility, and a third is for the ACDelco(R) Powertrain Registration Center. The Registration Center copy is a pre-addressed, postage paid mailer.

The installation facility will be responsible for completion and proper handling of the Powertrain Warranty Registration Form. The installation facility should present the customer the completed warranty registration form, as well as a copy of the repair order, in a specially provided vinyl envelope (WA-39ENV). Finally, the ACDelco(R) copy of the Powertrain Registration Form should be mailed promptly to the Powertrain Registration Center for processing. Upon receipt, ACDelco(R) will confirm the warranty registration by mailing the consumer a Thank You letter.

Additional quantities of the ACDelco(R) Engine Warranty Statement, WA-39, and the ACDelco(R) Powertrain Warranty Registration Form, WA-39A, are available through Vispac by calling 1-734-266-5018 and ordering form WA-39 and/or WA-39A.

This warranty provides for independent repair facilities to perform warranty repairs on failed ACDelco(R) remanufactured engines. However, independent repair facilities that purchase ACDelco(R) Remanufactured Engines from a GM dealer must obtain authorization from the dealer to do the work under sublet. (See consumer warranty statement in the GM Service Policies and Procedures Manual Article 1.1, Section B - ACDelco(R) Remanufactured Engine Limited Warranty.)

Warranty Claim Submission Requirements

All repairs or replacements of the ACDelco(R) engines MUST be pre-approved through the ACDelco(R) Powertrain Center on 1-800-ACDelco (1-800-223-3526). The hours of operation are Monday through Friday (except holidays) from 8:00 a.m. to 6:30 p.m. Eastern Standard Time. The ACDelco(R) Powertrain Center will reach agreement with dealership personnel regarding the appropriate repair, answer any technical questions, and will provide you with a Warranty Claim Tracking Number which will be required for the comments section of the DCS warranty claim input screen.

Effective September 15, 1999, WINS will restrict payment of all ACDelco(R) engine claims that have not been pre-authorized through the

1-800-ACDelco Powertrain Center (1-800-223-3526). Any claims which fail to have the required pre-authorization will return with either of the following error messages: PF- Call 1-800-ACDelco, LS- Labor op requires wholesale authorization. In the event you receive one of these error messages on an ACDelco(R) engine warranty claim, contact 1-800-ACDelco immediately for assistance.

To provide you with quality service, the ACDelco(R) Powertrain Center requests the following information be available prior to contacting 1-800-ACDelco: Vehicle Identification Number (VIN), Mileage at installation, Current Mileage, Serial # of the failed ACDelco(R) engine, Make/Model/Year of vehicle, Complaint/Prior History, Failed Part Number.

Claim Submission Details

- ^ Repair Order Number
- ^ Repair Order Date
- ^ Claim Tracking Number - Enter the claim tracking number provided by the ACDelco(R) Powertrain Center into the Inbound Comments Section of your DCS claim entry screen. Refer to the General Motors Claims Processing Manual or your DCS Vendor Manual for further instructions.
- ^ Vehicle Identification Number - Enter full VIN regardless of year or make.
- ^ Mileage - Enter the actual mileage on the vehicle at the time of repair.
- ^ SV-ADV-SS - Enter the Service Advisor's social security number
- ^ PC - Part Count. Total number of parts used in the repair.
 - ^ Part Number - the GMSPO part number of the failed ACDelco(R) remanufactured engine assembly or applicable failed part number if a repair to the assembly is performed.
- ^ TOT-PTS - Enter the pre-approved total cost plus applicable handling allowance for all parts used in the repair.
- ^ Compliant Code/Failure Code - See "Appendix A and B" of the General Motors Claims Processing Manual dated March, 1999.
- ^ Labor Operation Hours - Enter pre-approved labor hours agreed with the ACDelco(R) Powertrain Center.
- ^ Labor Operation Number - Enter R9200.
- ^ Other Labor Hours - Not allowed.
- ^ Sublet/Dealer Material - Sublet amounts, if applicable.
- ^ Technician ID - repairing technician's social security number.
- ^ Enter claim type "B" for claims within 12 months/12,000 miles from date and mileage of purchase.
- ^ Enter claim type "N" for claims after 12 months/12,000 miles from the date/mileage of purchase up to 24 months/24,000 miles for engines purchased prior to February 1, 1999, or 36 months/36,000 miles from date/mileage of purchase for engines purchased after February 1, 1999.
- ^ Authorization Code - leave this field blank.

Important:

Core credit will be issued by the GMSPO PDC and must not be a part of the warranty claim. As a reminder, you must affix the red "Warranty Claim" sticker to the Core Return Tag on all warranted ACDelco(R) engines returned to the GMSPO PDC for core credit.

The ACDelco(R) Powertrain Center will also assist in the following areas:

- ^ Answer technical questions about the product and catalog.
- ^ Answer questions concerning warranty coverage and provide claim tracking numbers for warranty claim processing.
- ^ Provide assistance in obtaining appropriate support materials, ordering information and core shipping information.
- ^ Provide a customer referral service for Dealers selling ACDelco(R) engines.
- ^ Authorize all ACDelco(R) engine claims for payment.

Important:

ACDelco(R) remanufactured engines are intended solely for the retail customer pay market and are not to be used for new vehicle warranty repairs

or policy adjustments. Any GM New Vehicle Warranty obligation or policy adjustment decision requiring engine replacement is to be satisfied using a replacement engine identified in GMSPO catalog groups 0.000, 0.000A, or 0.000B for the applicable vehicle. **Technical Service Bulletin # 87-61-24**

Date: **980401**

Engine - Surface Conditioning Discs Precautions

File In Section: 6 - Engine

Bulletin No.: 87-61-24

Date: April, 1998

INFORMATION

Subject:

Use of "Surface Conditioning Discs"

Models:

1998 and Prior Passenger Cars and Trucks

The Use of "Surface Conditioning Discs"

When cleaning engine gasket sealing surfaces, and/or cleaning parts from an engine which are to be reused; surface conditioning discs (typically a woven fiber pad design) which contain abrasives, such as a high amount of Aluminum Oxide, are not recommended.

The use of such surface conditioning discs dislodge Aluminum Oxide (from the Disc) and metal particles, which can lead to premature engine bearing failure.

The presence of Aluminum Oxide in engine oil has been shown to cause premature engine bearing failure. In some cases this failure occurs in as little as 1,000 miles (2,200 km) or less after the repair has been made.

Surface conditioning discs may grind the component part material and imbed it into the disc. This can result when more aggressive grinding of the gasket surface takes place.

Procedure

A new product from 3M(R) Automotive Aftermarket Division, the Roloc Bristle Disc*, is now available which addresses some of the above concerns.

* We believe this product to be reliable. There may be additional manufacturers of such products. General Motors does not endorse, indicate any preference for or assume any responsibility for any items which may be available from this firm, or for any such items which may be available from other sources.

Caution:

- ^ To avoid personal injury follow standard safety precautions, including the use of safety glasses, should be observed during surface preparation
- ^ Read the Safety Instructions included with the product before use.

Remove by hand, with a scrapper (plastic scrapper on aluminum surfaces), the bulk of material on the component surface before using the 3M(R) Roloc Bristle Disc.

Notice:

- ^ Due care must be taken to avoid the entry of any material into the engine block oil and coolant passages when cleaning component surfaces.
- ^ The presence of foreign material in engine oil has been shown to cause premature engine bearing failure.

Cover or block all engine ports (engine oil and coolant) and open areas (cylinder bores, lifter valley, etc.) to prevent possible contamination when working on the engine.

Vacuum up all contaminants (i.e. dirt, gasket material, etc.).

Important:

Engine components, cleaned with 3M(R) Roloc Bristle Disc, should be thoroughly cleaned before re-installing them on the engine block.

The use of a vacuum, spray cleaner GM P/N 12346139 or 12377981, parts cleaner, etc. to remove all traces of contaminant is suggested.

3M® Part Number**	Color/Description***	Suggested Application	Quan.
	White 120X Grit Roloc Bristle Disc	Aluminum (Mild Abrasive)	Box of 10
07532	1" Diameter		
07528	2" Diameter		
07529	3" Diameter		
	Yellow 80X Grit Roloc Bristle Disc	Aluminum or Cast Iron/Steel (Medium Abrasive)	Box of 10
07531	1" Diameter		
07525	2" Diameter		
07527	3" Diameter		
	Green 50X Grit Roloc Bristle Disc	Cast Iron/Steel (Harsh Abrasive)	Box of 10
07530	1" Diameter		
07524	2" Diameter		
07526	3" Diameter		

*** The above 3M® Roloc Bristle Discs are to be used with the correct Disc Pad Assemblies listed below.

3M® Part Number**	Description	Quantity
05538	1" Roloc Disc Pad Assembly	Box of one (1)
05539	2" Roloc Disc Pad Assembly	
05540	3" Roloc Disc Pad Assembly	

Notice: When using any abrasive material, particularly on aluminum surfaces, care must be taken to avoid damage to the surface area. Excessive material removal may result in damage to sealing surfaces.

** These components can be obtained from local 3M® suppliers. The brand names "3M" and "Roloc" are trademarks of Minnesota Mining and Manufacturing Company, St. Paul, Minnesota 55144.

Figure 1 - 3M® Roloc Bristle Disc Identification

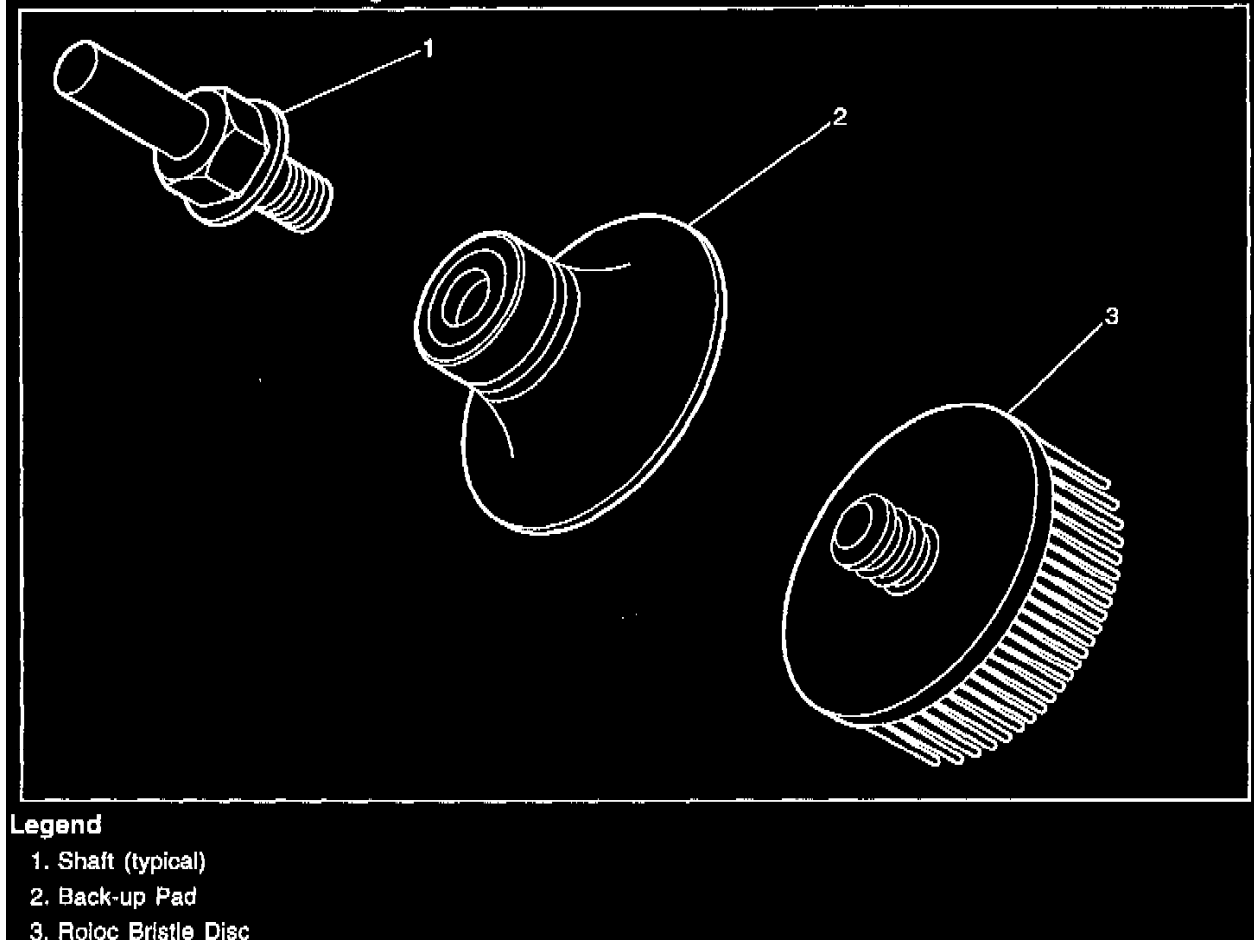

The Discs (see Figure 1 - 3M(R) Roloc Disc Identification) are available in different grit levels, with suggested applications as shown:

Caution:

Non-3M(R) Back-up pad's may have a deeper threaded cavity which causes the button (on the Disc) to continue to tighten down during use. This can cause the button to separate from the disc resulting in disc fly off and potential operator harm.

Parts Information

Part Numbers	Description
12346139, 12377981	Spray Cleaner

Parts (spray cleaners only) are currently available from GMSPO.

Technical Service Bulletin # 576128

Date: 950901

Engine Mechanical - New Tool Application

File In Section: 6 - Engine

Bulletin No.: 57-61-28

Date: September, 1995

SERVICE MANUAL UPDATE

Subject:
Section 6A - Engine Mechanical - New J Tool Application

Models:	
1994-96	Buick Road master
1994-96	Cadillac Fleetwood
1992-96	Chevrolet Corvette

1993-96 Chevrolet Camaro
1994-96 Chevrolet Caprice, Impala 55
1993-96 Pontiac Firebird

with 4.3L, 5.7L Engines (VINs W, P - RPOs L99, LT1)

This bulletin provides updated information regarding special tools.

New J tool 41546 can be used to service all water pump driveshaft assemblies. J tool 39092 can only be used to service 1992 and 1993 V8 LT1 applications.

Technical Service Bulletin # **87-65-27**

Date: **981201**

Engine - Miss/Poor Driveability

File In Section: 6E Engine Fuel & Emission

Bulletin No.: 87-65-27

Date: December, 1998

Subject:

Engine Miss/Poor Driveability Symptoms

(Install Opti-Spark (ABITS) Distributor Assembly Service Kit)

Models:

1994-96 Buick Roadmaster

1994-96 Cadillac Fleetwood

1992-96 Chevrolet Corvette

1993-97 Chevrolet Camaro

1994-96 Chevrolet Caprice

1993-97 Pontiac Firebird/Trans Am

with 4.3L or 5.7L Engine (VINs W, P, 5 - RPOs L99, LT1, LT4)

Condition

Some vehicles with the above engines and equipped with the Opti-Spark (ABITS) ignition system may exhibit an engine miss and/or poor driveability symptoms.

Cause

The (ABITS) cap and rotor may exhibit carbon tracking, cracking, or water intrusion which can cause an engine miss and/or poor driveability symptoms.

Correction

Perform strategy-based diagnosis. If it is determined that the ABITS cap and/or rotor is the source of the concern, then a service kit may be now implemented instead of a complete ABITS assembly.

Parts Information

There are two (2) variations of Opti-Spark Distributors. It will be mandatory to identify which type is to be serviced for proper parts procurement.

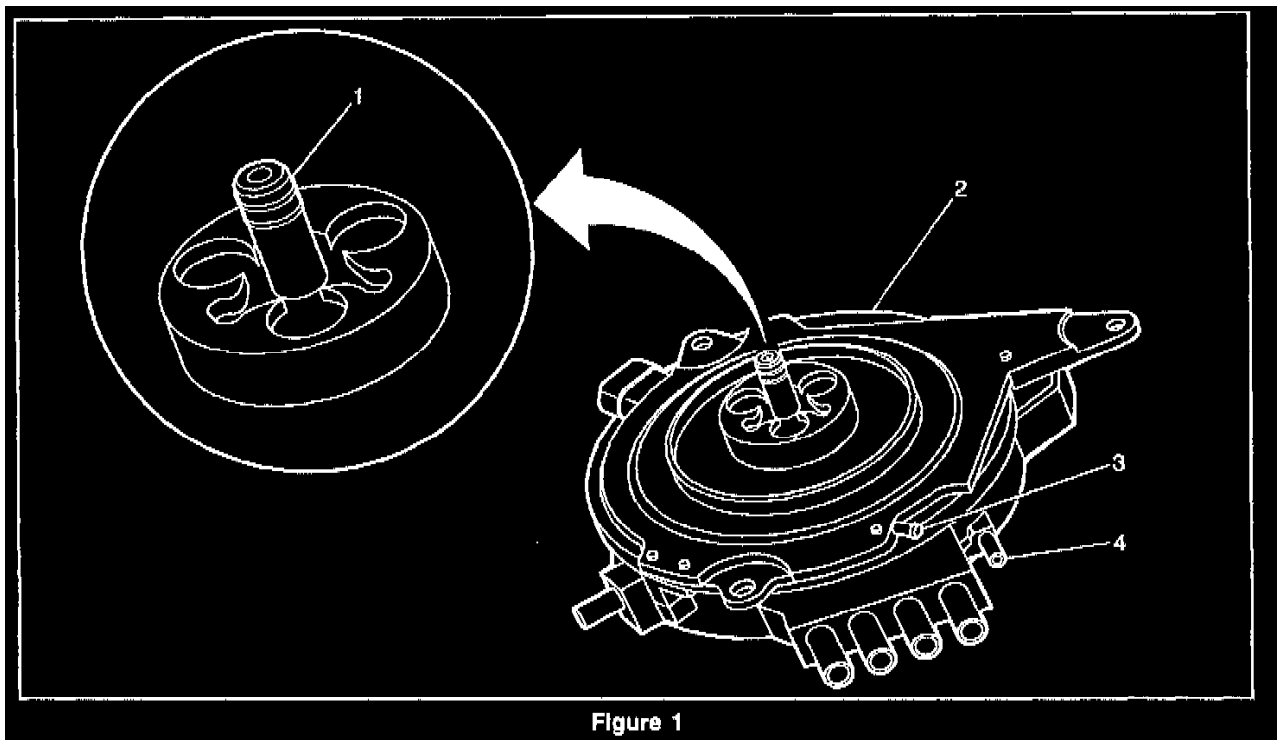

Figure 1

1. Opti-Spark Distributor II (Pin Drive - WITH positive vent system) can be identified by the intake manifold vacuum hose connection (3), air intake duct hose connection (4), or non-splined pin drive (1). Refer to Figure 1.

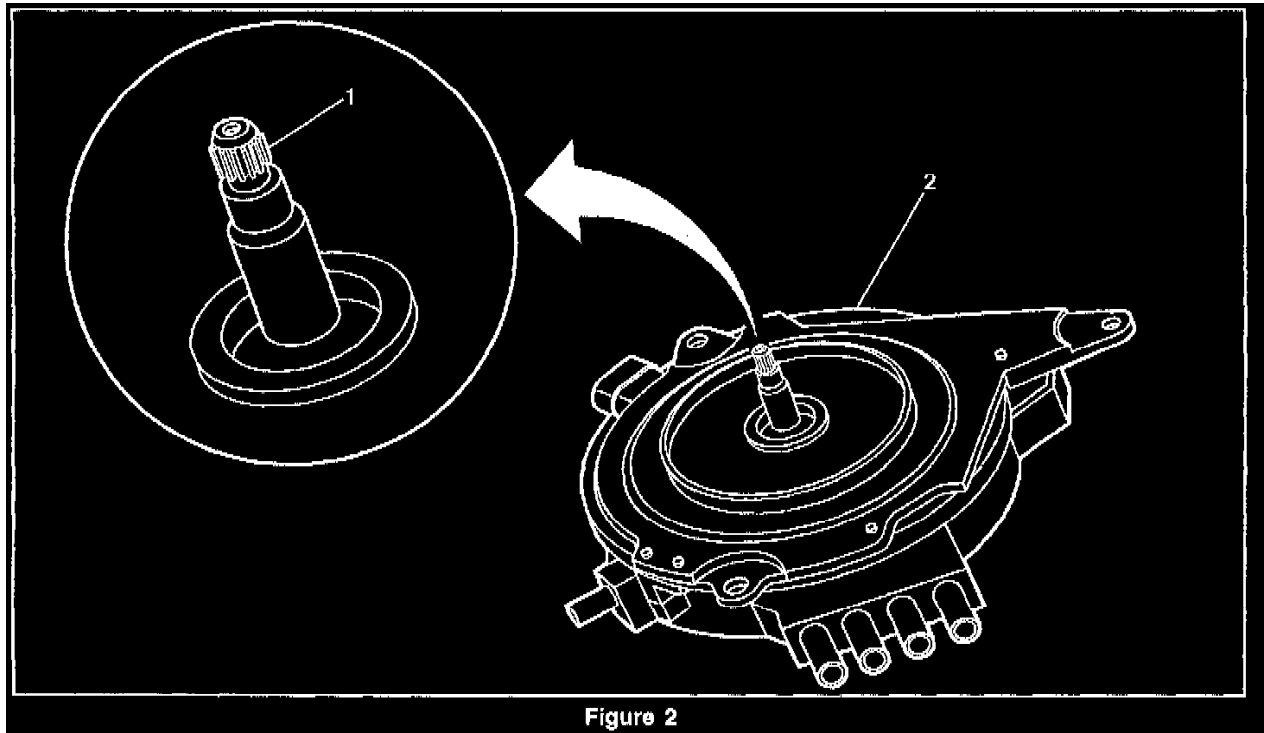

Figure 2

2. Opti-Spark Distributor I (Splined Drive - WITHOUT positive vent system) can be identified by the splined pin drive (1), or the lack of intake manifold vacuum hose connection and air intake duct hose connection. Refer to Figure 2.

Distributor	P/N	Application	Kit Contents
Opti-Spark I (Spine Drive) (No Vent)	10457735	92-94 Y 93-94 F	Distributor cap, rotor, screws, and washers
Opti-Spark II (Pin Drive) (Positive Vent)	10457293	94-96 B,D 95-96 Y 95-97 F	Distributor cap, rotor, cover, screws, and washers

Important:

it is necessary to use tool J 39997 (or equivalent) for the Distributor Cap Screws and tool J 39998 (or equivalent) for the Rotor Screws. Parts are currently available from GMSPO.

Warranty Information

For vehicles repaired under warranty, use:

Labor Operation

Labor Time

J4520 (B/D/F Cars)
J4360 (Y Car)

Use published labor operation time

Technical Service Bulletin # 77-61-17

Date: 971001

Engine - Oil Leaks Between Intake Manifold and Block

File In Section: 6.- Engine

Bulletin No.: 77-61-17

Date: October, 1997

Subject:

Oil Leaks Between Intake Manifold and Engine Block
(Reseal the Mating Surfaces)

Models:

1992-96 Chevrolet Corvette
1993-97 Chevrolet Camaro
1993-97 Pontiac Firebird with 5.7L Engine (VINs P, 5 - RPOs LT1, LT4)

Condition

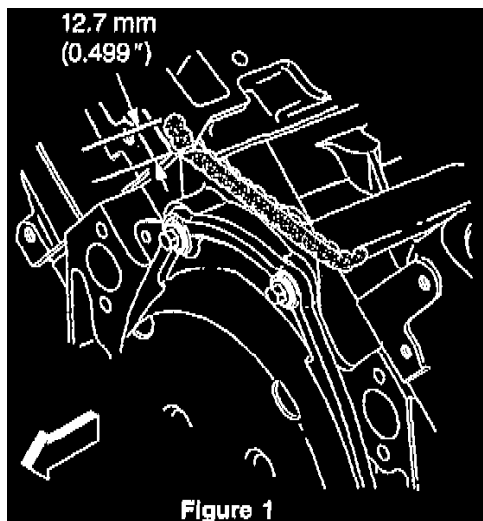

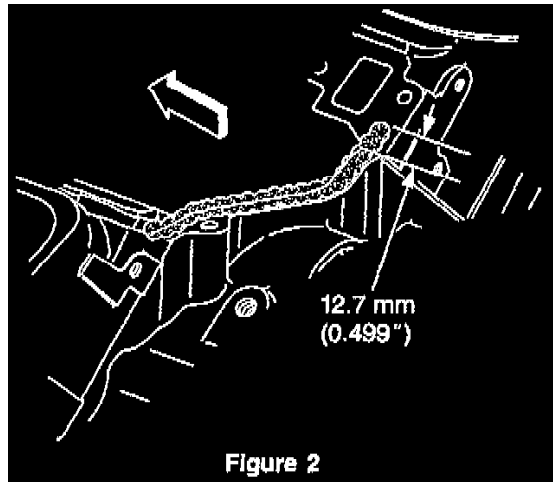

Oil leaks at mating surfaces between the intake manifold and engine block. Sometimes called "China Wall." (See Figures 1 and 2).

Cause

Insufficient RTV bonding between the intake manifold and cylinder block.

Correction

It is very important to identify the source of the leak. Clean and dry area thoroughly before inspection. Use black light and oil dye to identify the source. If the China Wall area is found to be the source of the leak, reseal the mating surfaces with "3 BOND" RTV (P/N 12346141).

We believe this source and their product to be reliable. There may be additional manufacturers of such products. General Motors does not endorse, indicate any preference for or assume any responsibility for the products from this firm or for any such items which may be available from other sources.

It is extremely important that the mating surfaces be properly cleaned before applying the RTV.

Scrape off original sealer and any foreign material from the intake manifold and engine block. Avoid scratching surfaces and do not allow any debris to fall into the engine. Do not use any type of high speed rotary discs.

Wipe surfaces clean with a clean dry cloth and cleaner solvent. Pay particular attention to the four corners where the heads meet the front and rear china wall area of the block. Again ensure that particles DO NOT fall into the engine. Wipe surfaces clean with a clean dry cloth and cleaner solvent.

Prime the mating surfaces with the new RTV sealant by rubbing the surfaces with a small amount of wet RTV on a clean cloth. Then wipe off the excess RTV.

Firmly apply a 1/4 inch (5 mm) diameter bead of RTV into each of the four corners where the heads meet the block. Then, apply a 1/4 inch (5 mm) bead of RTV to the front and rear areas of the engine block, going up the cylinder heads approximately 3/8 to 1/2 inch (10 to 12.7 mm). (See Figures 1 and 2).

While RTV is still wet, install the intake manifold and gaskets per service manual procedures. Take care not to push the RTV out of position. After assembling the engine, let RTV cure for at least 2 hours before driving vehicle.

Warranty Information

For vehicles repaired under warranty, use:

Labor Operation	Labor Time
J0200	Use published labor operation time

Technical Service Bulletin # 536107

Date: 960101

Engine Oil Pan - Revised Service Procedure

File In Section: 6 - Engine

Bulletin No.: 53-61-07

Date: January, 1996

SERVICE MANUAL UPDATE

Subject:

Section 6A3A - Revised Engine Oil Pan Service Procedure for Auto Transmission, New Procedure for Manual Transmission

Models:

1993-96 Chevrolet Camaro

1993-96 Pontiac Firebird

with 5.7L Engine (VIN P - RPO LT1)

This bulletin revises the engine oil pan service procedure for the above listed vehicles equipped with the automatic transmission and includes a service procedure for the manual transmission.

Automatic Transmission

Remove or Disconnect

1. Negative battery cable.
2. Intake air temperature (IAT) sensor electrical connector.
3. Resonator and air intake duct from throttle body.
4. Raise and suitably support vehicle. Refer to Section OA of the Service Manual.
5. Drain engine oil.
6. Oxidation catalytic converter. Refer to Section 6F of the Service Manual.
7. Exhaust pipe hanger bolt/screw and reposition pipe.
8. Starter motor. Refer to Section 6D2 of the Service Manual.
9. Transmission converter cover. Refer to Section 7A of the Service Manual.
10. Engine mount through bolts/screws.
11. Raise engine with jacking fixture.
12. Electrical connector from oil level sensor.
13. Oil level sensor.
14. Transmission oil cooler lines from clip at pan bracket.
15. Oil pan bolts/screws, studs and nuts.
16. Oil pan, reinforcements and gaskets.

Important: Rotate crankshaft to reposition counterweights, if necessary.

Install or Connect

1. Oil pan gasket, oil pan and reinforcements.
2. Oil pan bolts/screws, studs and nuts.

Tighten

- ^ Tighten corner oil pan bolts/screws, studs or nuts to 20 N.m (15 lb. ft.).
- ^ Tighten remainder of oil pan bolts/screws to 12 N.m (106 lb. in.).

3. Transmission oil cooler lines to clip at pan bracket.
4. Oil level sensor.
Tighten
Tighten oil level sensor to 22 N.m (16 lb. ft).
5. Electrical connector to oil level sensor.
6. Lower engine and remove jacking fixture.
7. Engine mount through bolts/screws.
Tighten
Tighten engine mount through bolts/screws to 95 N.m (70 lb. ft).
8. Transmission converter cover. Refer to Section 7A of the Service Manual.
9. Starter motor. Refer to Section 6D2 of the Service Manual.
10. Exhaust pipe hanger bolt/screw.
11. Oxidation catalytic converter. Refer to Section 6F of the Service Manual.
12. Lower vehicle.
13. Refill with engine oil.
14. Resonator and air intake duct to throttle body.
15. Intake air temperature (IAT) sensor electrical connector.
16. Negative battery cable.
Tighten
Tighten negative battery cable to 15 N.m (11 lb. ft).

Manual Transmission

Remove or Disconnect

1. Negative battery cable.
2. Intake air temperature (IAT) sensor electrical connector.
3. Resonator and air intake duct from throttle body.
4. Raise and suitably support vehicle. Refer to Section 0A of the Service Manual.
5. Drain engine oil.
6. Starter motor. Refer to Section 6D2 of the Service Manual.
7. Flywheel housing cover.
8. Manual transmission. Refer to "6-Speed Manual Transmission" in Section 7B of the Service Manual.
9. Support engine.
10. Engine mount through bolts/screws.
11. Oil filter and adapter.

12. Oil level sensor electrical connector.
13. Oil level sensor.
14. Oil pan bolts/screws, studs and nuts.
15. Raise engine.
16. Oil pan, reinforcements and gasket.

Important: Rotate crankshaft to reposition counterweights, if necessary.

Install or Connect

1. Oil pan gasket, oil pan and reinforcements.
2. Lower engine.
3. Oil pan bolts/screws, studs and nuts.

Tighten

- ^ Tighten corner oil pan bolts/screws, studs or nuts to 20 N.m (15 lb. ft.).
- ^ Tighten remainder of oil pan bolts/screws and nuts to 12 N.m (106 lb. in.).

4. Oil level sensor.

Tighten

Tighten oil level sensor to 22 N.m (16 lb. ft).

5. Oil level sensor electrical connector.
6. Oil filter and adapter.
7. Engine mount through bolts/screws.

Tighten

Tighten engine mount through bolts/screws, to 95 N.m (70 lb. ft).

8. Manual transmission. Refer to "6-Speed Manual Transmission" in Section 78 of the Service Manual.
9. Remove engine support.
10. Flywheel housing cover.

11. Starter motor. Refer to Section 6D2 of the Service Manual.

12. Lower vehicle.

13. Refill with engine oil.

14. Resonator and air intake duct to throttle body.

15. Intake air temperature (AT) sensor electrical connector.

16. Negative battery cable.

Tighten

Tighten negative battery cable to 15 N.m (11 lb. ft.).

Engine - Use of Wacker RTV Sealant for Intake Manifold

File In Section: 6 - Engine

Bulletin No.: 67-61-17A

Date: August, 1996

Subject:

Use of Wacker T-330 RTV Sealant
(Pronounced Vaucker T)

Models:

1990-96 Buick Roadmaster, Estate Wagon

1990-96 Cadillac Fleetwood

1990-96 Chevrolet Camaro, Caprice, Corvette, Impala SS

1990-92 Oldsmobile Custom Cruiser

1990-96 Pontiac Firebird

with 4.3L, 5.7L Engine (VINs W, P, 5, 8 - RPOs L99, L98, LT1, LT4)

1990-96 Chevrolet and GMC Light and Medium Duty Trucks with 4.3L, 5.0L, 5.7L, 6.0L, 7.0L, 7.4L Engines
(VINs W, Z, E H, K, M, N, P, R - RPOs L35, LB4, L03, L05, LS0, LR0, L19, L30, L31)

This bulletin is being revised to add further Chevrolet models. Please discard Corporate Bulletin Number 67-61-17 (Section 6 - Engine).

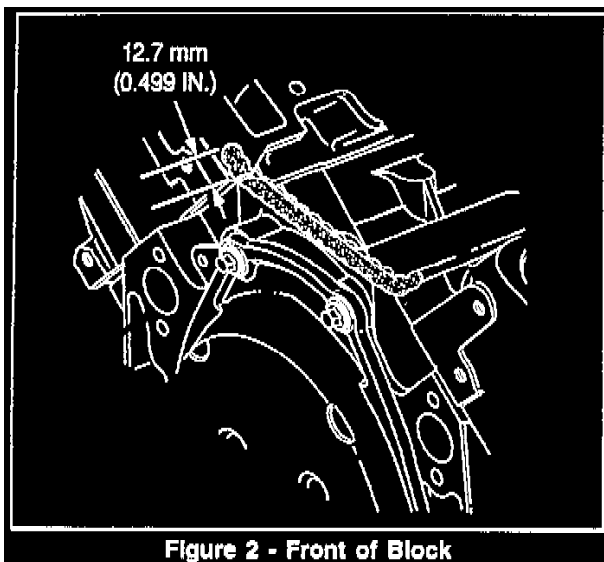
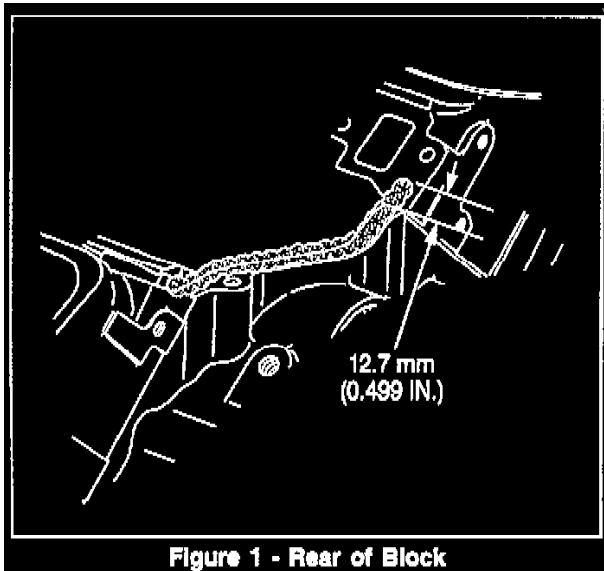

When installing the intake manifold, use a 5 mm (1/4 in.) thick bead of Wacker T-330 RTV, P/N 12346192, on the front and rear sealing areas between

the engine block and intake manifold. See Figures 1 and 2. Wacker T-330 RTV has improved adhesive abilities, is oxygen sensor safe, and is noncorrosive to ferrous metals. Wacker T-330 RW cannot be used in coolant sealing surface areas.

Technical Service Bulletin # **416525**

Date: **941001**

DI System - Chart C-4 Revised

File In Section: 6E - Engine Fuel & Emission

Bulletin No.: 41-65-25

Date: October, 1994

SERVICE MANUAL UPDATE

Subject:

Section 6E3 - Driveability and Emissions - Revised Chart C-4

Models:

1994	Buick Roadmaster
1994	Cadillac Fleetwood
1992-94	Chevrolet Corvette
1993-95	Chevrolet Camaro
1993-95	Pontiac Firebird with 5.7L Engine (VIN P - RPO LT1)
1994	Chevrolet Caprice with 5.7L and 4.3L Engines (VINs P, W - RPOs LT1, L99)

CONSULT THE APPROPRIATE SERVICE MANUAL FOR WIRING DETAILS

CHART C-4A

DISTRIBUTOR IGNITION (DI) SYSTEM CHECK

Chart Test Description: Number(s) below refer to circled number(s) on the diagnostic chart.

1. The battery should be fully charged prior to any tests. Check for proper output from the distributor ignition system. The spark tester requires a minimum of 25,000 volts to fire. This check can be used in case of an ignition miss, because the system may provide enough voltage to run the engine but not enough to fire a spark plug under heavy load.
2. This test will separate the distributor cap, rotor and ignition wires from the ignition coil to help identify a secondary ignition system problem. It is necessary to unscrew the top terminal on the ST 125 spark tester for a proper fit in the distributor end of the coil wire.
3. This will determine if the proper available voltage exists in the primary ignition circuit.
4. A grounded coil circuit will cause the ignition fuse to open, and a no-start condition will occur.

Diagnostic Aids: An ignition coil wire that is open or shorted to ground can cause a no start condition.

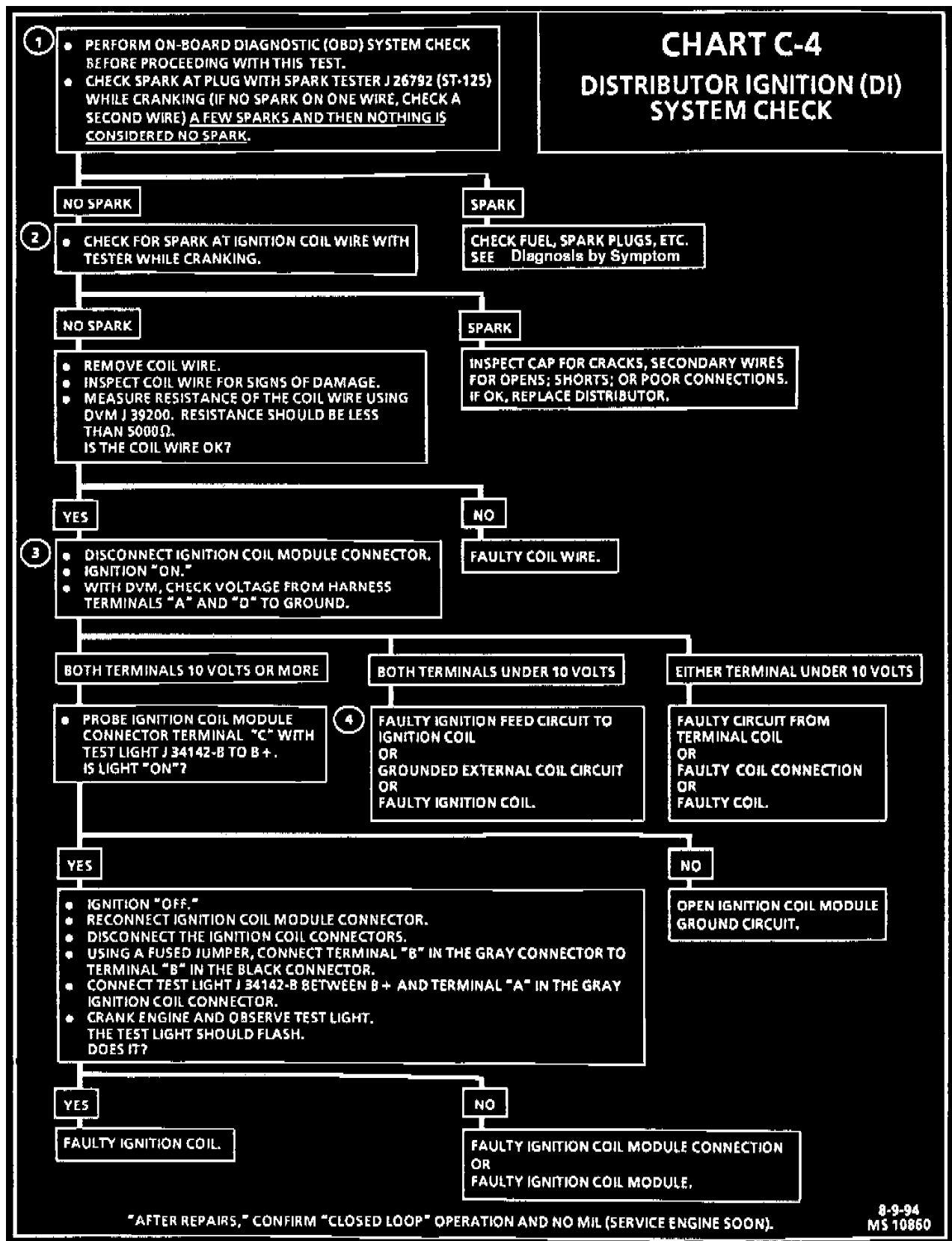

This bulletin updates the Distributor Ignition (DI) System Check in Section 6E3-Chart C-4. Use the chart and facing page provided in place of the existing Chart C-4 and facing page in the Service Manuals affected.

Technical Service Bulletin # 04-06-01-013

Date: 040401

Engine - Serpentine Drive Belt Wear Information

Bulletin No.: 04-06-01-013

Date: April 29, 2004

INFORMATION

Subject:
Information on Serpentine Belt Wear

Models:
2004 and Prior Passenger Cars and Trucks
2003-2004 and Prior HUMMER H2

All current GM vehicles designed and manufactured in North America were assembled with serpentine belts that are made with an EPDM material and should last the life of the vehicle. It is extremely rare to observe any cracks in EPDM belts and it is not expected that they will require maintenance before 10 years or 240,000 km (150,000 mi) of use.

Older style belts, which were manufactured with a chloroprene compound, may exhibit cracks depending on age. However, the onset of cracking typically signals that the belt is only about halfway through its usable life.

A good rule of thumb for chloroprene-based belts is that if cracks are observed 3 mm (1/8 in) apart, ALL AROUND THE BELT, the belt may be reaching the end of its serviceable life and should be considered a candidate for changing. Small cracks spaced at greater intervals should not be considered as indicative that the belt needs changing.

Any belt that exhibits chunking should be replaced.

GM bulletins are intended for use by professional technicians, NOT a "do-it-yourselfer". They are written to inform these technicians of conditions that may occur on some vehicles, or to provide information that could assist in the proper service of a vehicle. Properly trained technicians have the equipment, tools, safety instructions, and know-how to do a job properly and safely. If a condition is described, DO NOT assume that the bulletin applies to your vehicle, or that your vehicle will have that condition. See your GM dealer for information on whether your vehicle may benefit from the information.



WE SUPPORT
VOLUNTARY
TECHNICIAN
CERTIFICATION

Disclaimer Technical Service Bulletin # **02-06-01-008**

Date: **020301**

Engine - New PreLube Tool

File In Section: 06 - Engine/Propulsion System

Bulletin No.: 02-06-01-008

Date: March, 2002

INFORMATION

Subject:
Information on a New Engine PreLuber Tool

Models:
1990-2002 All Cars and Light Duty Trucks

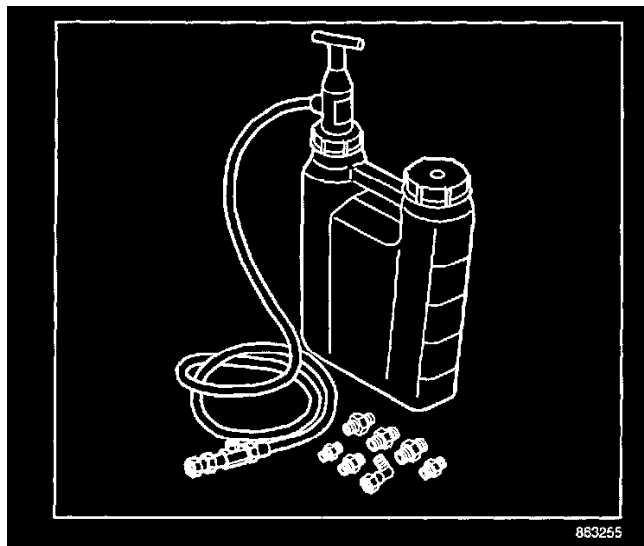

A new engine Preluber tool has been developed as an essential tool. This tool will be automatically shipped to all tier one and tier two dealerships. The new tool is known as J-45299 ENGINE PRELUBER.

The J-45299 ENGINE PRELUBER consists of a two gallon container, hand pump, flexible hose, adapter set and a two sided laminated instruction sheet. The engine preluber will inject clean engine oil into the engine oiling system. Following the instructions included with the tool will allow the main bearings, connecting rod bearings and the oil pump to be properly lubed.

When prelubing the engine with more than the minimum recommended amount of oil, the camshaft bearings and other valve train components may also be lubricated.

Notice:

Neglecting to prelude or improperly prelubing a new, remanufactured or serviced engine prior to the initial start-up may lead to premature bearing failure in the engine.

This tool should be used when installing a new engine, remanufactured engine or an overhauled engine. This tool and procedure should also be used when the crankshaft or connecting rods have been removed from the engine for any reason.

Any dealers or other interested parties can purchase this tool directly from Kent Moore by calling 1-800-345-2233.

GM bulletins are intended for use by professional technicians, NOT a "do-it-yourselfer". They are written to inform these technicians of conditions that may occur on some vehicles, or to provide information that could assist in the proper service of a vehicle. Properly trained technicians have the equipment, tools, safety instructions, and know-how to do a job properly and safely. If a condition is described, DO NOT assume that the bulletin applies to your vehicle, or that your vehicle will have that condition. See your GM dealer for information on whether your vehicle may benefit from the information.



WE SUPPORT
VOLUNTARY
TECHNICIAN
CERTIFICATION

Disclaimer Technical Service Bulletin # **04-07-30-013B**

Date: **070201**

Engine, A/T - Shift/Driveability Concerns/MIL ON

Bulletin No.: 04-07-30-013B

Date: February 01, 2007

INFORMATION

Subject:

Automatic Transmission Shift, Engine Driveability Concerns or Service Engine Soon (SES) Light On as a Result of the Use of an Excessively/Over-Oiled Aftermarket, Reusable Air Filter

Models:

2007 and Prior GM Cars and Light Duty Trucks

2007 and Prior Saturn Models

2003-2007 HUMMER H2

2006-2007 HUMMER H3

2005-2007 Saab 9-7X

Supercede:

This bulletin is being revised to add models and model years. Please discard Corporate Bulletin Number 04-07-30-013A (Section 07 - Transmission/Transaxle).

DO THIS	DON'T DO THIS
First, Inspect the vehicle for a reusable aftermarket excessively/over-oiled air filter	DO NOT repair MAF sensors under warranty if concerns result from the use of an excessively/over-oiled aftermarket, reusable air filter.

The use of an excessively/over-oiled aftermarket, reusable air filter may result in:

Service Engine Soon (SES) light on

Transmission shift concerns, slipping and damaged clutch(es) or band(s)

Engine driveability concerns, poor acceleration from a stop, limited engine RPM range

The oil that is used on these air filter elements may be transferred onto the Mass Air Flow (MAF) sensor causing contamination of the sensor. As a result, the Grams per Second (GPS) signal from the MAF may be low and any or all of the concerns listed above may occur.

When servicing a vehicle with any of these concerns, be sure to check for the presence of an aftermarket reusable, excessively/over-oiled air filter. The MAF, GPS reading should be compared to a like vehicle with an OEM air box and filter under the same driving conditions to verify the concern.

The use of an aftermarket reusable air filter DOES NOT void the vehicle's warranty.

If an aftermarket reusable air filter is used, technicians should inspect the MAF sensor element and the air induction hose for contamination of oil prior to making warranty repairs.

Transmission or engine driveability concerns (related to the MAF sensor being contaminated with oil) that are the result of the use of an aftermarket reusable, excessively/over-oiled air filter are not considered to be warrantable repair items.

GM bulletins are intended for use by professional technicians, NOT a "do-it-yourselfer". They are written to inform these technicians of conditions that may occur on some vehicles, or to provide information that could assist in the proper service of a vehicle. Properly trained technicians have the equipment, tools, safety instructions, and know-how to do a job properly and safely. If a condition is described, DO NOT assume that the bulletin applies to your vehicle, or that your vehicle will have that condition. See your GM dealer for information on whether your vehicle may benefit from the information.



WE SUPPORT
VOLUNTARY
TECHNICIAN
CERTIFICATION

Disclaimer Technical Service Bulletin # 05-00-89-072B

Date: 080617

Engine/Fuel System - Oil/Fuel Additive Information INFORMATION

Bulletin No.: 05-00-89-072B

Date: June 17, 2008

Subject:
Fuel and Oil Additives - Facts and Myths/Maximizing Fuel Economy

Models:
2009 and Prior GM Passenger Cars and Trucks (including Saturn)
2009 and Prior HUMMER H2, H3
2009 and Prior Saab 9-7X

Attention:

Please direct this bulletin to the Service Manager, the Service Consultants and the Sales Staff. A copy of this bulletin is encouraged to be given to your customer as it is written with the consumer in mind. You may also post this bulletin in your customer lounge or waiting area.

Supersede:

This bulletin is being revised to add the 2009 model year. Please discard Corporate Bulletin Number 05-00-89-072A (Section 00 - General information).

A Statement About Fuel Economy

As gasoline prices have increased, the consumer has shifted priorities to become increasingly concerned with fuel consumption. GM is presently proud to offer over 30 cars in the U.S. with EPA highway estimates of at least 30 mpg. In Canada, vehicles are rated for fuel consumption in liters per 100 kilometers. GM offers over 20 vehicles in Canada that consume less than 7.0 L/100 km on the highway. The information below contains reasonable and prudent advice for your dealership and the consumer to get the most from every gallon or liter of gas.

The information below is presented in two easy to understand sections:

^ What Not To Do: Engine and Fuel Additives, Alternate Fuels, and "Miracle" Products

^ What to Do: Maximizing Fuel Economy/Minimizing Costs

WHAT NOT TO DO: Engine and Fuel Additives, Alternate Fuels, and "Miracle" Products

Various unproven products with claims to improve vehicle fuel economy have been reported ranging from magnets that align molecules to chemical combustion improvers.

Most products claiming to provide benefits are based on unsubstantiated claims. Those that do present "scientific" results generally either have too little supporting data to be conclusive, have not conducted experiments in a controlled fashion, or cannot be substantiated by anyone else but the product's manufacturer.

The U.S. Federal Trade Commission summarizes results for products tested by the federal government at www.ftc.gov/bcp/edu/pubs/consumer/autos/aut10.shtm. A review of the list shows that the majority did not work, and for those that showed some effect, the benefit was too small to be cost effective.

Harmful Ideas That May Damage Your Vehicle and Increase Emissions

One more recent poor idea to improve fuel economy that should not be attempted is to blend either kerosene or diesel fuel into gasoline. Why? Both kerosene and diesel fuel are distillate fuels meant for use in compression ignition engines, not spark ignition engines. They have very low octane and since they are heavier (higher density) than gasoline, they will cause heavy engine deposits and degradation of engine oil.

Notice:

Never put Kerosene or Diesel Fuel in your Gasoline Engine vehicle. This may result in inconsistent performance and permanent damage to your vehicle that is not covered by your New Vehicle Warranty.

Chemicals that are normally used as solvents also should not be used. These include acetone, ketones, and methanol. These solvents can be incompatible with your vehicles rubber or sealing components, and may dissolve the vehicle's paint finish. In the case of methanol, corrosion of metal parts in the fuel system also may occur.

Notice:

Never use acetone, ketones, or methanol additives in your vehicle. Some of these solvents may damage or corrode your fuel system. They are also very damaging to the painted surfaces of the vehicle if spilled. Damage to vehicle components that result from non-approved or aftermarket additives and devices are not covered under the terms of the New Vehicle Warranty. The only fuel additive currently approved by GM is GM Fuel System Treatment Plus, P/N 88861011 (in Canada, # 88861012).

WHAT TO DO: Maximizing Fuel Economy/Minimizing Costs

The best fuel economy possible is the direct result of proper maintenance and good driving habits. Listed below are GM's recommendations to achieve the best mileage possible. The first group are things to consider for your vehicle, while the second are tips relating to your driving habits.

Vehicle Considerations:

^ Tire Pressure - One of the major contributors to poor fuel economy are under inflated tires. Tires low on pressure create drag that the vehicle's powertrain must overcome, wasting dollars in fuel. Always keep your tires inflated to the proper pressure as shown on the vehicle placard. This not

only serves to increase gas mileage but cuts down on tire wear, further decreasing your costs per mile.

^ Air Filter - A vehicle that has a dirty air filter can't efficiently draw air into the engine. This restriction forces the engine to expend energy to "breathe" wasting fuel in the process. Change recommendations are found in your vehicle Owner's Manual.

^ Proper Viscosity "Starburst" Rated Oil - Always use the proper viscosity oil in your engine. Oil that has a higher than required viscosity will create more drag on the internal components of the engine, causing more work for it, especially when cold. Each Owner's Manual contains information on the proper type of oil for your vehicle. Look for the "starburst" symbol on the front of the bottle, and the SM rating on the API circle on the back label. If you are in doubt, stop by your dealer for an oil change, and any other services required. Most current GM vehicles are equipped with oil life monitors to further assist on the "when" to change your oil. (Aveo/Wave/Oprtra/Epica currently do not have oil life monitors).

Notice:

GM Vehicles DO NOT require additional engine oil additives. Some additives may cause harmful effects to the internal seals and additionally void the terms of your vehicles New Car Warranty.

^ Top Tier Fuels - Some fuel manufacturers provide gasoline advertised as TOP TIER DETERGENT GASOLINE (Chevron, Conoco, Phillips 66, Shell, Texaco, Entec Stations, MFA Oil Company, 76, Somerset Oil, Aloha Petroleum, Tri-Par Oil Company, QuikTrip, and Kwik Trip) in the U.S. and (Petro-Canada, Chevron, Shell, and Sunoco) in Canada. These fuels are preferable when and where available. They help to keep your fuel injectors and intake valves free of deposits. Clean engines provide optimal fuel economy, performance and reduced emissions. When Top Tier fuels are not available, consider a bottle of GM Fuel System a bottle of GM Fuel System treatment PLUS, P/N# 88861011 (in Canada, # 88861012), at oil change time which will remove intake system and injector deposits. GM does not recommend any other fuel system cleaner.

Important:

DO NOT confuse Top Tier Fuels with Higher Octane (Plus/Premium Grade Fuel) commonly sold at most all gas stations. Plus and Premium fuels are required in some high performance GM vehicles. However, they do not necessarily represent higher detergency present in TOP TIER Detergent Gasoline.

Important:

For additional information regarding Top Tier fuels and availability, please refer to Corporate Bulletin Number 04-06-04-047G for U.S. or 05-06-04-022D for Canada.

Notice:

E85 FUELS: Only vehicles designated for use with E85 should use E85 blended fuel. E85 compatibility is designated for vehicles that are certified to run on up to 85% ethanol and 15% gasoline. All other gasoline engines are designed to run on fuel that contains no more than 10% ethanol. Use of fuel containing greater than 10% ethanol in non-E85 designated vehicles can cause driveability issues, service engine soon indicators as well as increased fuel system corrosion. See Corporate Bulletin Number 05-06-04-035C for additional information.

^ Use the Recommended Grade (Octane) Fuel

Purchasing higher than required octane fuel is a waste of money. Using higher octane fuels in a vehicle that only required regular unleaded fuel will neither increase performance nor improve gas mileage. In all cases refer to your owners manual and ONLY use the octane rated fuel recommended for your vehicle.

Important:

In high performance GM vehicles that DO require Premium (91 octane or higher) fuel, you MUST use fuels of at least this octane. Use of lower octane fuel may result in reduced performance, knocking, and/or permanent engine damage not covered under the terms of the New Vehicle Warranty.

^ Check Engine/Service Engine Soon Light - Is the Check Engine/SES light on? When this light is on, the vehicles On-Board diagnostics computer has noticed that something is wrong. GM vehicles have many sensors that the computer uses to both control and sense actual fuel usage. When the computer lights the Check Engine/SES light it has lost some ability to run efficiently. This may result in increased fuel consumption, increased emissions, and/or driveability concerns.

^ Spark Plugs - Even though most current GM vehicles have 160,000 km (100,000 mi) service intervals for spark plugs, if your vehicle is at that point in its life, have the spark plugs changed to assure proper running and continued efficient, trouble free operation. Refer to the applicable Maintenance Schedule for spark plugs service intervals on Chevrolet Aveo, Oprtra, Epica, Pontiac Vibe, Wave and Saturn Astra.

Changes In Driving Habits:

^ Slow Down, Drive Smoothly - Avoid quick/full throttle acceleration from a standstill in town and high cruising speeds on the interstates. While the optimum MPG for highway cruising speed varies from vehicle to vehicle, faster is almost always worse. If your vehicle is equipped with a Driver Information Center that displays Instant Fuel Economy, select that read out and vary your cruising speed while on the highway. The display will change continuously with uphill and downhill sections but you should quickly be able to identify on level ground the speed range that your vehicle does the best in.

^ Empty Your Trunk - Avoid leaving unnecessary items in your trunk. It takes power to move increased weight and that means more gasoline consumption and reduced performance. While the change may be slight, multiplied by thousands of miles, it all adds up.

^ Avoid Extended Idling - There is no need to idle your engine till it reaches operating temperature. Idling wastes fuel.

^ Combine Trips - Your vehicle uses much more fuel when the engine is cold. This is especially true in the winter months when the engine will take the longest to warm up. Combine errands or trips so that the vehicle only needs to warm up once to encompass many different stops.

GM bulletins are intended for use by professional technicians, NOT a "do-it-yourselfer". They are written to inform these technicians of conditions that may occur on some vehicles, or to provide information that could assist in the proper service of a vehicle. Properly trained technicians have the equipment, tools, safety instructions, and know-how to do a job properly and safely. If a condition is described, DO NOT assume that the bulletin applies to your vehicle, or that your vehicle will have that condition. See your GM dealer for information on whether your vehicle may benefit from the information.



WE SUPPORT
VOLUNTARY
TECHNICIAN
CERTIFICATION

Disclaimer