

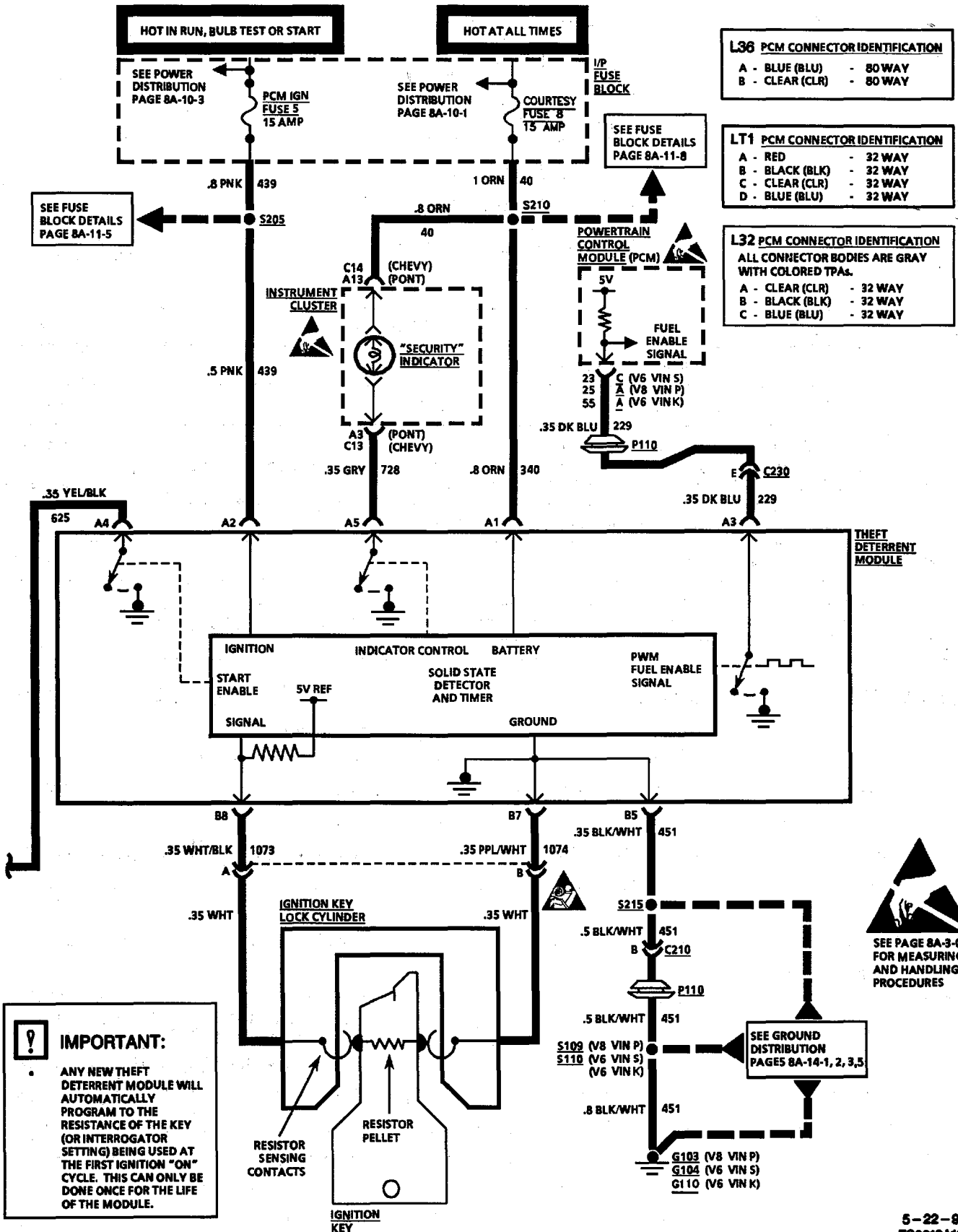

**THEFT DETERRENT SYSTEM: PASS-Key® II  
(PERSONALIZED AUTOMOTIVE SECURITY SYSTEM)**



**IMPORTANT:**

ANY NEW THEFT DETERRENT MODULE WILL AUTOMATICALLY PROGRAM TO THE RESISTANCE OF THE KEY (OR INTERROGATOR SETTING) BEING USED AT THE FIRST IGNITION "ON" CYCLE. THIS CAN ONLY BE DONE ONCE FOR THE LIFE OF THE MODULE.