

# Radio/Audio System Schematics (Cell 150: UL0, UM6, UN0 w/UQ0 or U62 (Chevrolet), and W52, W53 (Pontiac) Entertainment Systems)

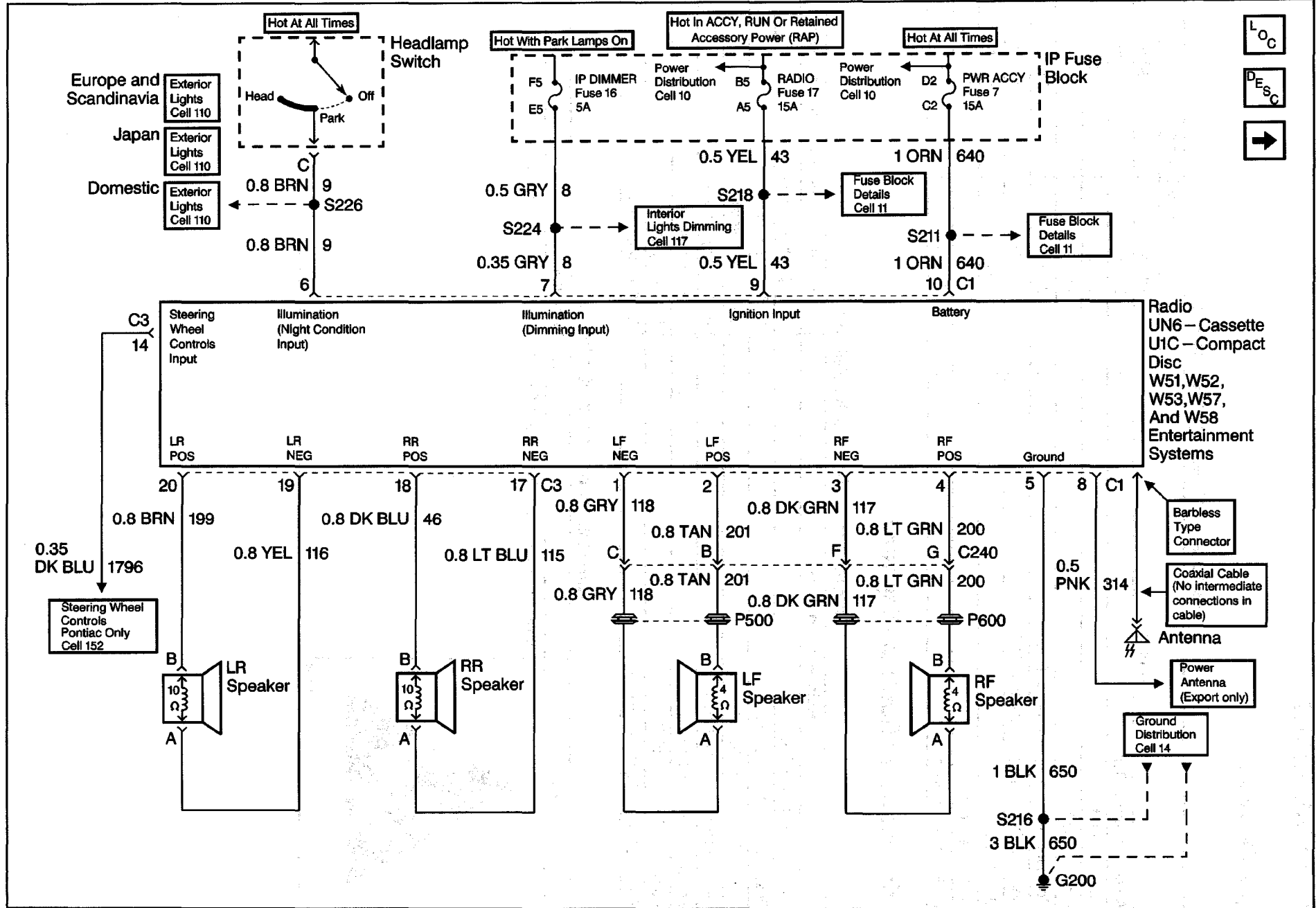

8-196 Entertainment

Body and Accessories

# Body Control Module Schematics (Without Door Jamb Switches) (RAP Components)

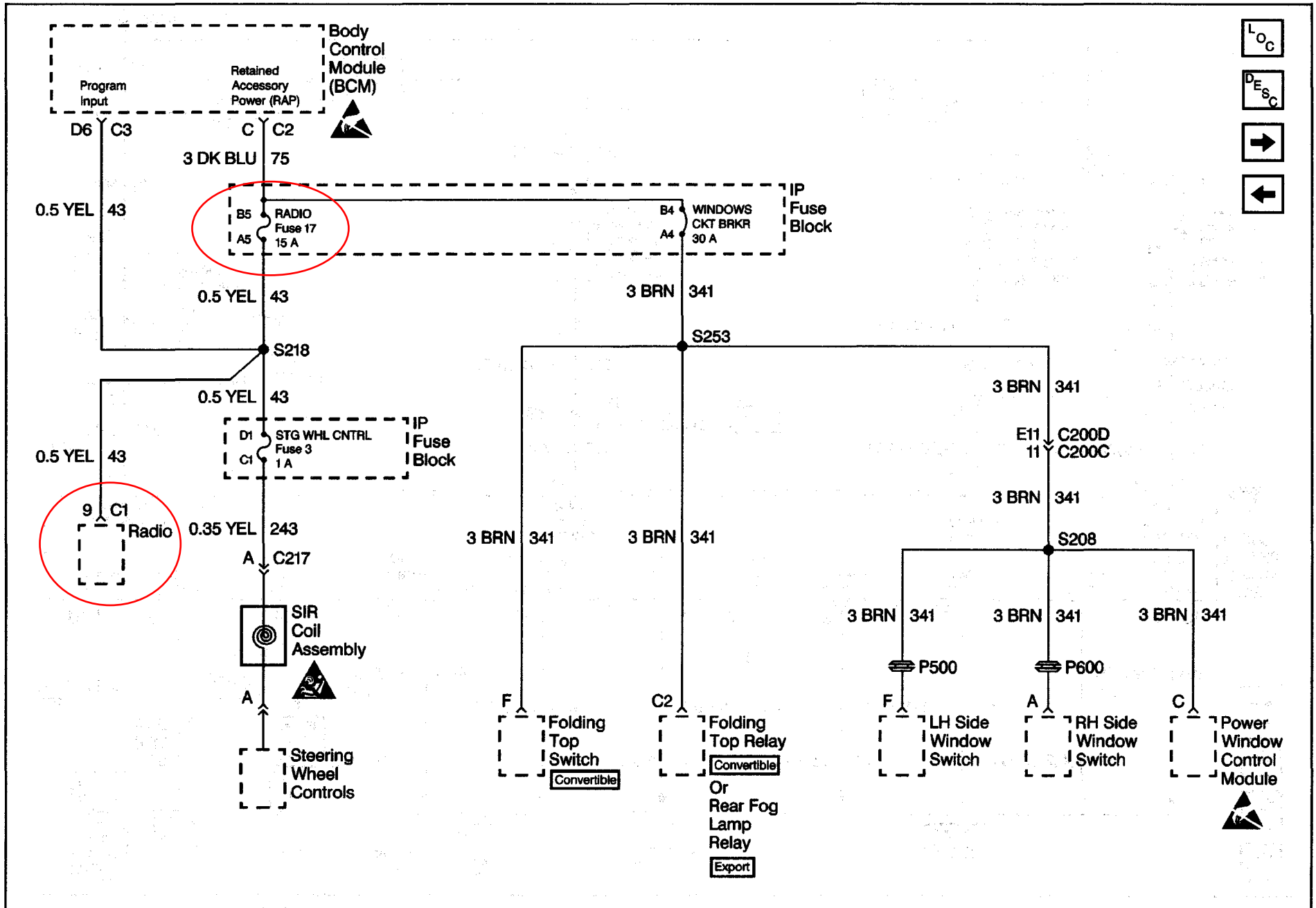

Fuse Block Details Schematics (Cell 11: CIG ACCY Fuse 11, PWR ACCY Fuse 7, AIR BAG Fuse 10, and GAUGES Fuse 9)

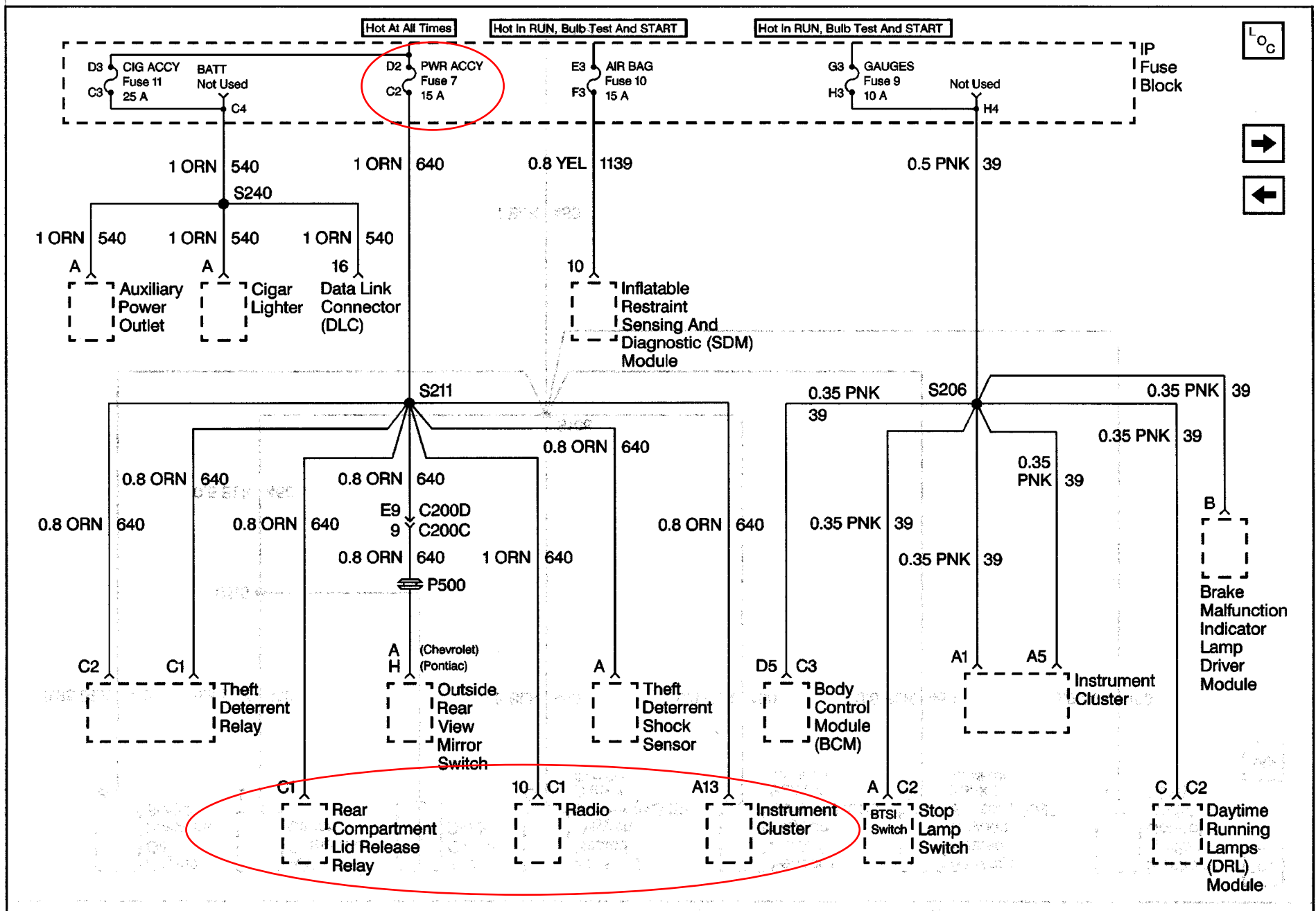

# Instrument Cluster: Analog Schematics (PCM and Engine Oil Pressure Sensor)

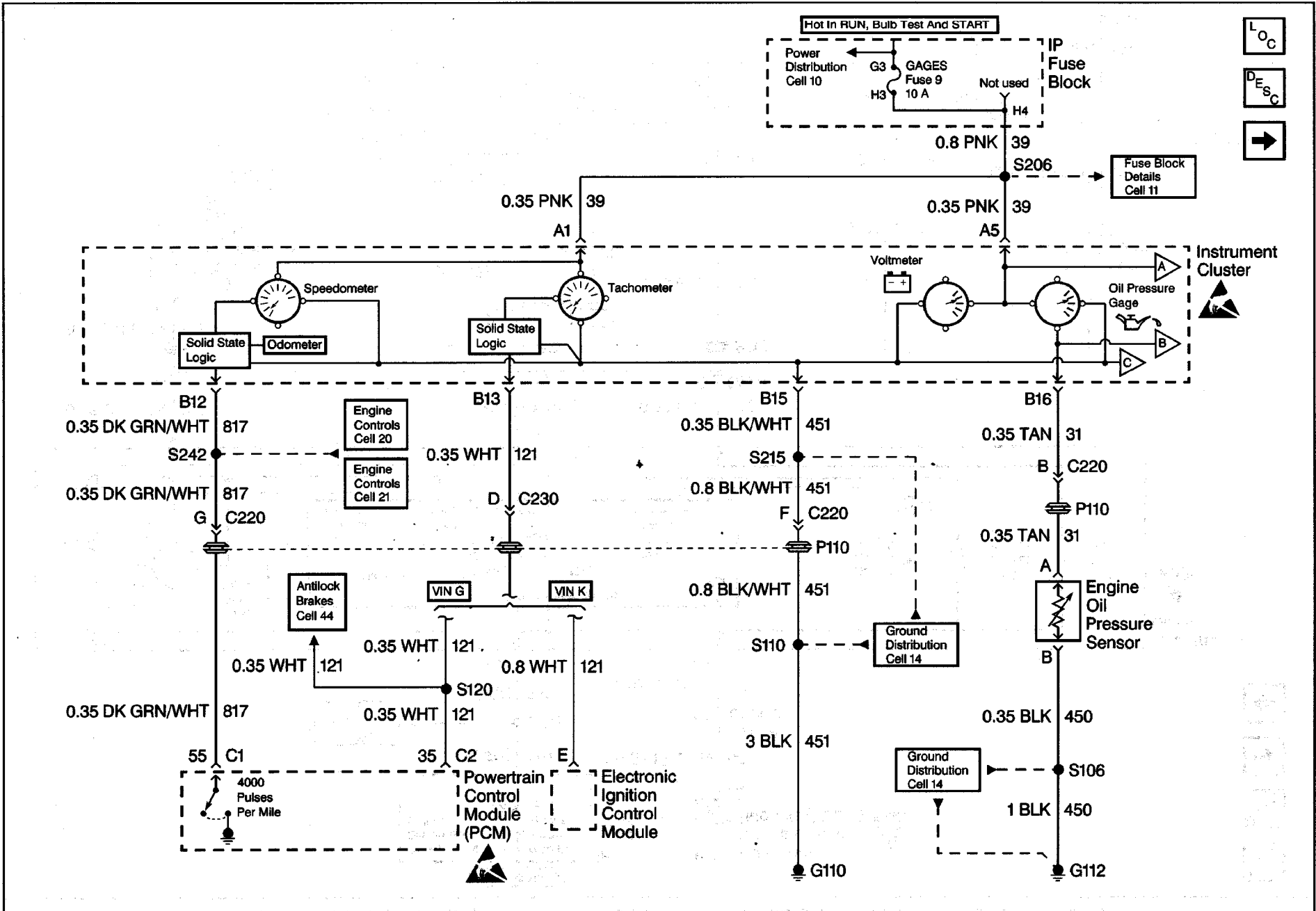

# Instrument Cluster: Analog Schematics (BCM and PCM)

